



Quick Start Guide REX 100 3G | LTE

Version

2^{en}
as of FW 1.5.0

Content

1. Introduction.....	3
2. Preparing the REX 100 unit.....	3
2.1 Connection.....	3
2.2 Optional wiring of IN1 and IN2.....	3
2.3 Antenna connections.....	4
3. Creating a REX 100 configuration in the myREX24 portal.....	5
3.1 Registration.....	5
3.2 Log in to the myREX24 portal.....	5
3.3 Creating a router configuration.....	6
4. Router configuration transfer options.....	8
4.1 Transferring the configuration using a USB flash drive.....	9
4.2 Configuration Transfer Manager (CTM).....	10
4.3 Transferring the configuration using a local LAN connection.....	14
5. Establishing a VPN connection to your REX 100.....	15
5.1 Establishing a VPN connection and transferring IP packages.....	15
5.2 Tips and tricks.....	15
6. Remotely servicing an Ethernet PLC.....	16
7. Description of LEDs and buttons.....	18
7.1 LED description.....	18
7.2 Button description.....	18
8. Restoring the REX 100 router to its default settings.....	18
9. Load configuration/firmware update from USB stick.....	18
10. Technical data.....	19
10.1 UL.....	20

1. Introduction

Before getting started:

Please use the most current version (as of v3) of the dual-up software "shDIALUP" for the commissioning.

Write down the serial number for your REX 100 router before installing the router in your system. You will need the serial number in order to configure the device!

The REX 100 is an industrial router designed to be installed on DIN rails and is suitable for worldwide remote access to IP-enabled devices (PLCs, HMIs, IP cameras, etc.)

This Quick Start Guide goes over the basic settings in the myREX24 portal and shows how to use the portal to create a configuration and transfer it to your REX 100 unit.

2. Preparing the REX 100 unit

Access to a GSM network requires a Standard SIM card of a provider: This is required for purposes of identification for the network operator. The insert is found on the housing side. The insert is unlocked by pressing the recessed yellow button next to the card reader and can be removed.

2.1 Connection

Now connect a supply voltage of 10–30 V DC to the provided connector for all device variants.

There is also a connection for the functional ground (FG). The connection of a functional ground is recommended.

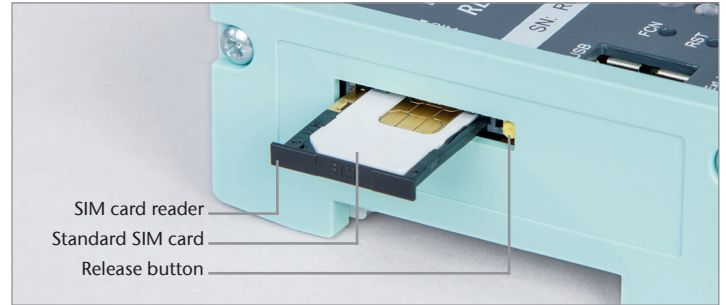

2.2 Optional wiring of IN1 and IN2

IN1: The establishing of the connection to the myREX24 server can, for example, be activated by an externally installed switch.

IN2: When the alarm management in the device has been activated and configured, e-mails, for example, can be sent through an externally installed button or relay contact.

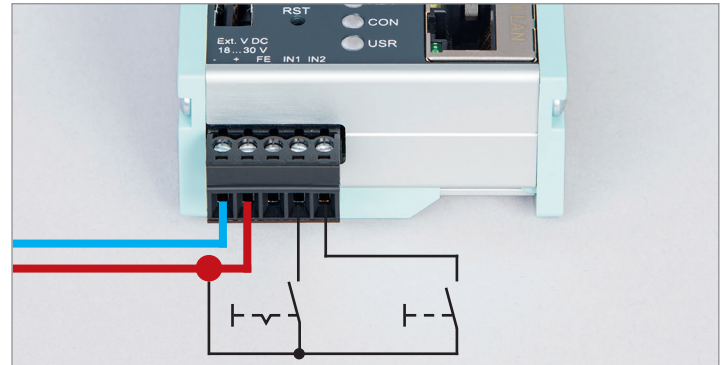

2.3 Antenna connections

Please note prior to installation that the antenna(s) must be positioned within the reception range of an adequate GSM signal. These may not be installed, for example, in metal housings. Please also observe the technical data sheets or instructions of the antenna manufacturer.

2.3.1 REX 100 3G (UMTS)

The antenna required for radio reception is screwed onto the SMA socket "ANT".

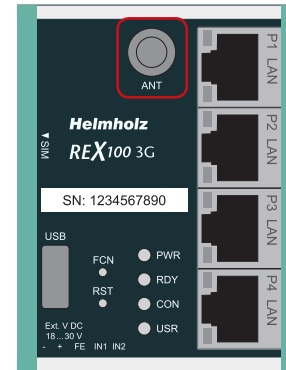

2.3.2 REX 100 LTE (4G)

For general radio reception, at least one antenna must be screwed onto the SMA socket "MAIN" (ANT 2).

An optional connection for a second reception antenna is available on the LTE router at the SMA socket "Rx" (ANT1) for improving the data throughput. This functionality is called antenna diversity in the "WCDMA mode" and Downlink-MIMO in the "LTE mode".

The second receiver antenna should not be located in the immediate vicinity of the main antenna. In order to improve the diversity gain and reduce other reciprocal interactions (interference effects), the two antennas should be (taking the space available for usage into account) installed with the greatest possible distance between them.

For the same reason, the second antenna should be mounted cross-polarized (with reference to the main antenna, 90° to one another).

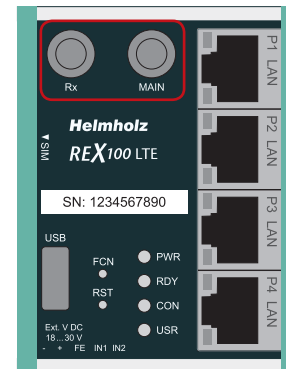

3. Creating a REX 100 configuration in the myREX24 portal

REX 100 routers are fully configured using the myREX24 portal. A completed configuration file can be transferred to the actual REX 100 unit in a variety of ways.

3.1 Registration

If you do not yet have a myREX24 account, you will first have to visit www.myREX24.net and register under "Request access". Make sure to fill out all mandatory fields. Once you submit the form, you will receive an e-mail containing your login data.

You can download the software necessary for establishing a connection with myREX24-Portal (shDIALUP and shCHECK), as well as other documents with supplementary example applications anytime from the download area under www.myREX24.net and www.helmholz.com.

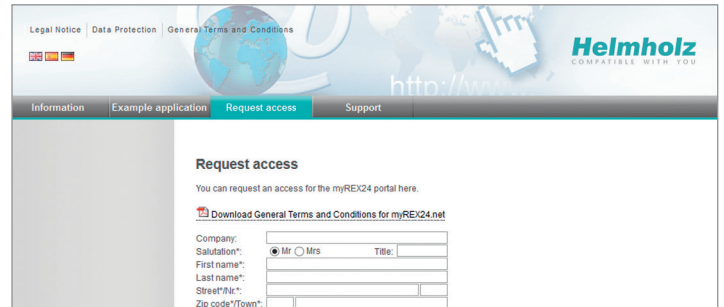

The screenshot shows the 'Request access' page of the myREX24 portal. The header includes 'Legal Notice', 'Data Protection', 'General Terms and Conditions', and the Helmholz logo with the tagline 'COMPATIBLE WITH YOU'. A navigation bar contains 'Information', 'Example application', 'Request access' (highlighted), and 'Support'. The main content area is titled 'Request access' and contains the text: 'You can request an access for the myREX24 portal here.' Below this is a link to 'Download General Terms and Conditions for myREX24.net'. A registration form follows with fields for: Company, Salutation* (radio buttons for Mr and Mrs), Title, First name*, Last name*, Street* / Nr.*, and Zip code* / Town*.

3.2 Log in to the myREX24 portal

Once you install and open the shDIALUP program, you can use your login data to log in to the myREX24 portal.

Note: Your login name is composed of a user name preceding the @ character and the name of your company.

Example: `admin@helmholz`

Other users can be created and administered after you log onto the myREX24 portal.

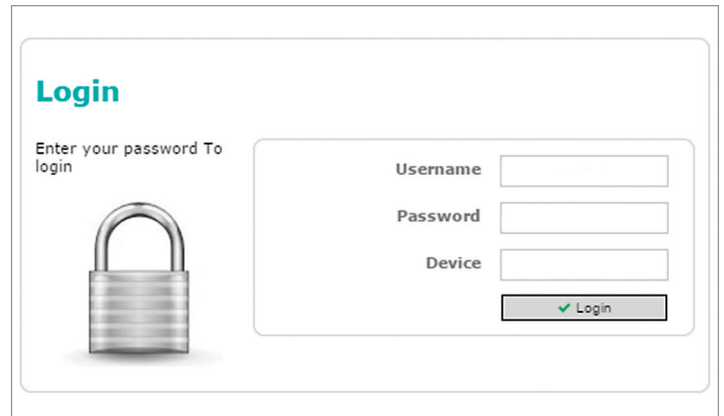

The screenshot shows the login page of the myREX24 portal. It features a large padlock icon on the left. The text 'Enter your password To login' is displayed. On the right, there is a login form with three input fields: 'Username', 'Password', and 'Device'. Below these fields is a 'Login' button with a green checkmark icon.

3.3 Creating a router configuration

The following information describes the configuration points required to establish a VPN portal connection. For a more detailed description of the advanced functions and configuration options available, please use the portal's online help.

Note: You should always individualize your login information (user names/passwords). You can find all relevant explanations in the online help.

Once a connection to the myREX24 portal is successfully established, a new browser window with your myREX24.net online account will open. Create a new device in the "Machines" menu.

Click the  icon to get to the next submenu.

Note: The device name must start with a letter. Umlauts, special characters and spaces are generally not permitted. In addition, every device name must be unique.

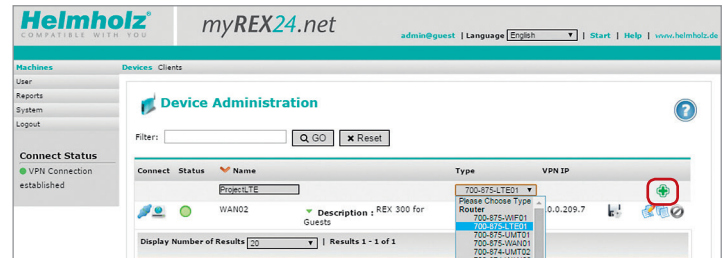

The description page for the device you just created will appear now. The entry of location and contact information data is optional.

If you have the telephone number of the SIM card available, you can enter this in the appropriate field so that the myREX24 portal can control the REX 100 with SMS messages.

The "Change VPN Password" field requires no entry. The password is generated automatically.

To make sure that the configuration is sent to the right device, you will need to enter the REX 100 router's serial number. The purpose of the additional description field is to make it possible to distinguish between several remote servicing units internally.

Open the "Network" tab without clicking "Save".

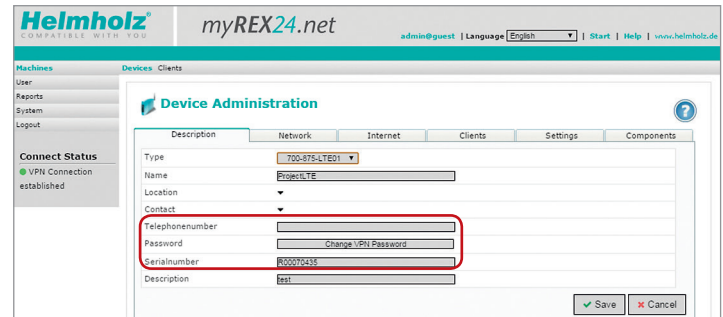

All REX 100 routers come with a LAN-side IP address of 192.168.0.100/24 as a default. Modify the IP address and the subnet mask in keeping with the specifications from the machinery network.

If you want to connect additional TCP/IP components to the REX 100 LAN interface for remote servicing purposes, this IP address will also be the default gateway for the connected devices (see page 16).

Open the "Internet" tab without clicking "Save".

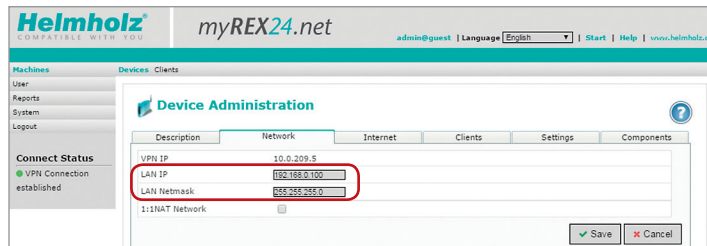

Under "Connect to the server", select the actions with which this device should connect to your myREX24 account.

In the case of "Modem settings", all information concerning the access point (Access Point Name) of the card provider must be provided and the SIM PIN entered.

You have now configured the basic settings and can click on "Save" to proceed to transfer the configuration to the REX 100 unit using one of the options available in the menu (see chapter 4, page 8).

In the event that the dialog for "Submit to Device" appears automatically, you can cancel this dialog and call it up later when needed.

Note: The myREX24 portal's online help provides information on the function of the advanced settings.

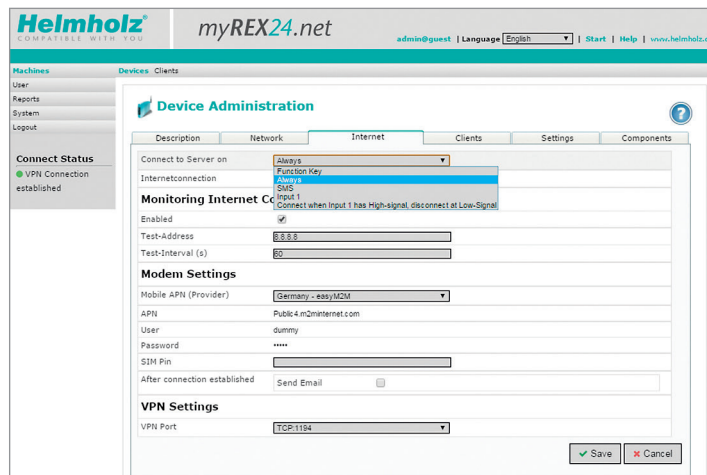

4. Router configuration transfer options

Once you have created a configuration, you can click the floppy disk icon in order to select one of three transfer methods.

1* Download configuration to PC

Save the configuration file and then use a USB stick to transfer it to the REX 100 unit (see chapter 4, page 9).

Choose this option if the REX 100 router cannot be reached through the local network (LAN) or through the Internet when it is first being set up.

2* Transfer configuration to CTM

The configuration is downloaded from the myREX24 portal using the REX 100 router's Internet connection (CTM=Configuration Transfer Manager; see chapter 4.2, page 10).

This Internet transfer method will become the default configuration option as soon as the REX 100 router has established a connection to the myREX24 portal. When the REX 100 has a connection to the myREX24 portal, the CTM is automatically used for all subsequent configuration changes.

3* Transfer configuration to device

The configuration is transferred via a local LAN connection of the computer on which shDIALUP is running (see chapter 4.3, page 14).

You can use this option if the REX 100 router can be reached directly through the local network (LAN).



4.1 Transferring the configuration using a USB flash drive

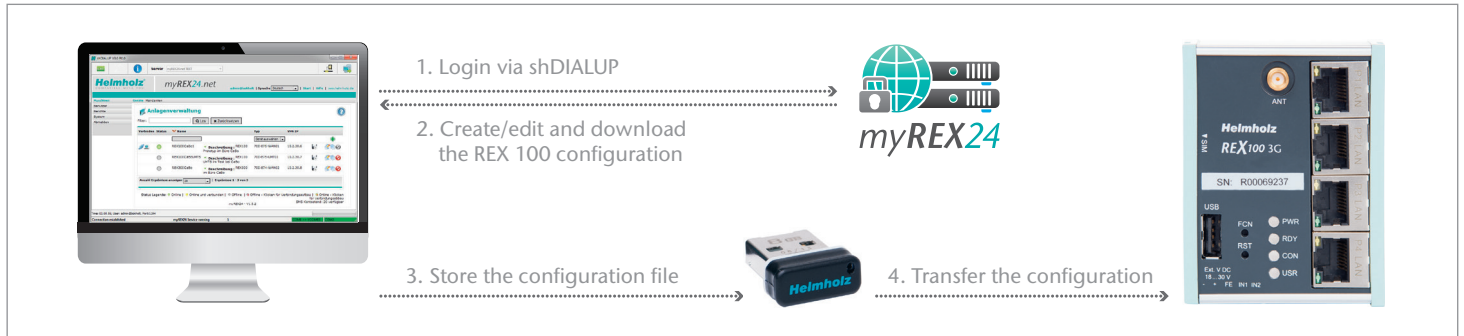

Use the USB-based configuration method if the REX 100 router can be reached neither through the local network (LAN) nor through the Internet.

In the myREX24 portal, go to the "Device Administration" page and select the "Download to PC" option.

Once the file has been stored on the local computer, carry out the steps as described in chapter 9 "Load configuration/firmware update from USB stick" on page 18.

4.2 Configuration Transfer Manager (CTM)

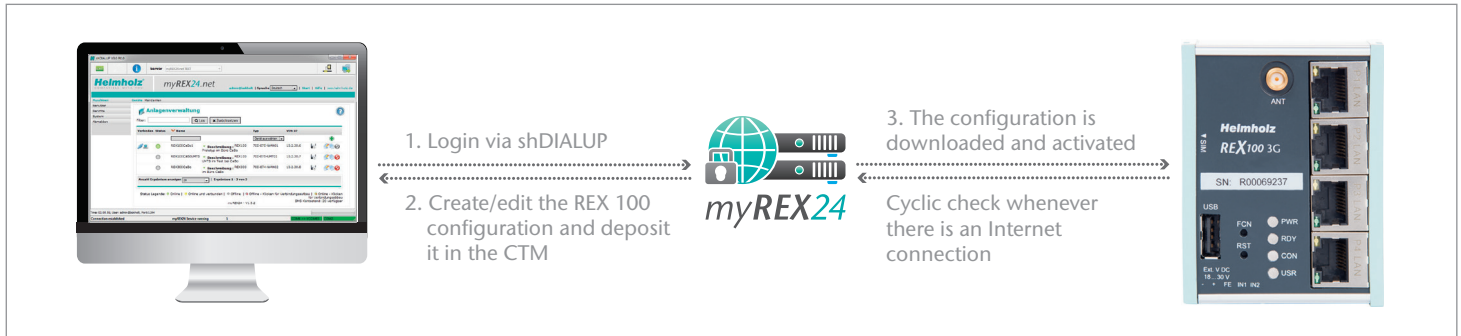

The Configuration Transfer Manager makes it possible to transfer a configuration to a REX 100 router once the router has established an Internet connection to the myREX24 portal.

If the REX 100 unit has a connection to the myREX24 portal, it will check whether there is a new configuration available for its serial number. If there is one, it will load it automatically. This method is ideal for retroactive changes to the configuration.

4.2.1 Establishing an Internet connection through the "First Start" website

If you have not yet configured your REX 100 router using one of the other configuration methods (directly on the computer or using a USB flash drive), you can also establish an Internet connection for the commissioning directly with the REX 100 router's web interface at the "First Start" website.

If the REX 100 can already set up an Internet connection, please continue to chapter 4.2.4 "Automatic download of the configuration" on page 12.

Commissioning via the "First Start" website presumes that the REX 100 can be addressed in the local network under its default IP address. REX 100 routers come with a default IP address of 192.168.0.100 (subnet mask: 255.255.255.0).

In order to be able to reach the REX 100 router, the PC network adapter must also be set to the IP address space and subnet of the router.

The device with serial number must be created in the myREX24 portal for successful commissioning.

Note:

- The CTM function is only supported as of version 3 of the dial-up software "shDIALUP".
- In order to be able to transfer the configuration, the Configuration Transfer Manager needs an Internet connection established using a SIM card. If you are commissioning your REX 100 unit for the first time, this can be commissioned directly on the REX 100 router through the "First Start" webpage.

Open the properties of your LAN connection in order to set the PC network card to the IP address range and the subnet of the router.

Windows¹ XP:

Start -> Settings -> Control Panel -> Network Connections

Windows¹ 7:

Start -> Control panel -> Network and sharing center -> Change adapter settings

Open the Properties dialog box for the network connection that you want to use in order to establish a connection to your REX 100 unit.

To change your computer's IP address, select "Internet Protocol (TCP/IP)" and click on the "Properties" button.

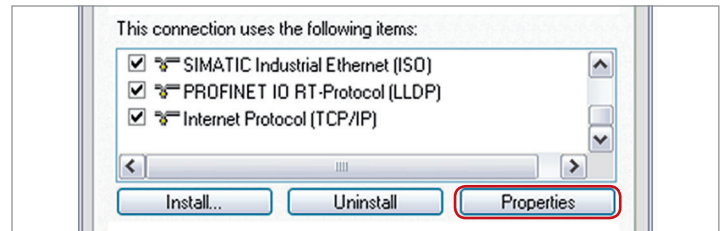

Your IP address must fall within the "192.168.0.x" address range. The subnet mask must match the subnet mask used by the REX 100 unit (default: 255.255.255.0).

Note: Make sure that there are no address space conflicts with any other network ports (do not assign the same IP address more than once). If there are, you will not be able to communicate with your REX 100 unit properly.

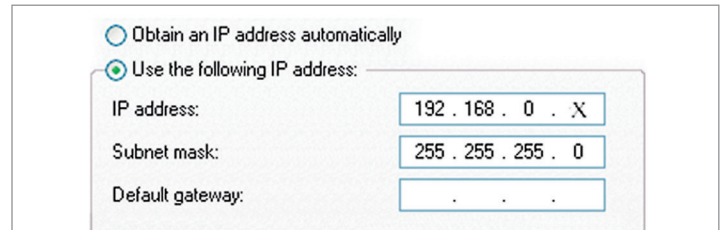

When your PC network card has accepted the new settings, start a browser (Firefox, Chrome, Opera) and enter the IP address of the router in the address line (URL) as follows: <http://192.168.0.100>.

Now enter the following default login data to successfully log in to the REX 100 unit:

User name: helmholz
Password: router

The Internet connection path of the REX 100 is now defined uniquely at the "First Start" website.

Note: For your own security, you must change the login data after setting up your router. To change them, go to the configuration menu on the myREX24 portal.

For the modem settings you will only need to provide the access data of the carrier (APN) and the SIM card ID number (SIM PIN).

Unittype: 700-875-LTE01 (1.5.0) Serialnumber: R00070425

Modem

Enter your settings for a modem->internet connection

Network (Provider)	Global-SIM easyM2M	User	dummy
Mobile APN (Provider)	public4.m2minet.com	Password	*****
SIM Pin	8888	Password Confirmation	*****

< Previous Next > Cancel

4.2.3 Conclude "First Start" steps

The default portal server does not have to be changed. The code for the session key is optional and does not have to be entered when setting up the router.

Unittype: 700-875-LTE01 (1.5.0) Serialnumber: R00070425

Cloudserver

Cloudserver settings

Cloudserverlist	User Defined
Cloudserver address/name	vpn2.myrex24.net
Session-Key	Session-Key

< Previous Next > Cancel

As soon as all settings have been transferred and saved in the REX 100 router, the router will establish an Internet connection.

Unittype: 700-875-LTE01 (1.5.0) Serialnumber: R00070425

Finish

Click on Apply to Save and Enable the Settings on the Device.

< Previous Apply Cancel

4.2.4 Automatic configuration download

If the REX 100 router is able to establish an Internet connection, it will connect to the myREX24 portal and verify itself using its serial number. Once a connection is successfully established, the "CON" LED on the router will start flashing (see LED description, chapter 7, page 18).

If a configuration file is available on the portal server, it will be automatically loaded onto the device and enabled.

4.2.5 REX 100 Quick Start status page





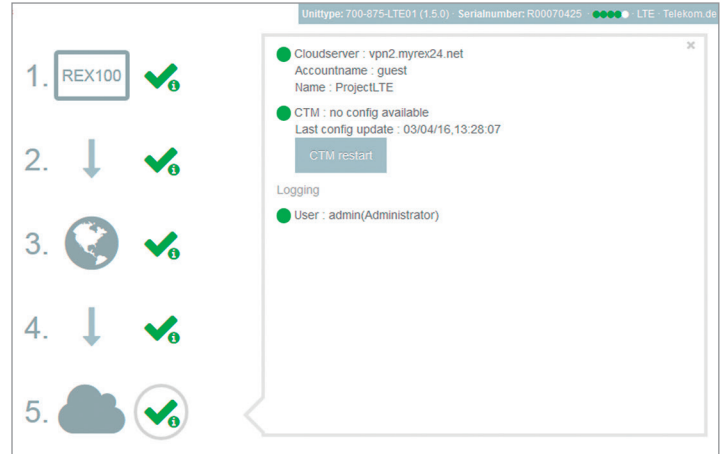

The status page on the REX 100 router's web interface will show the router's connection status and active configuration data.

To get more information on each step of the router connection, click on the  Info icon in the status fields.

You can use the status page to trigger test functions or to manually make the router obtain its configuration using the CTM.



Unittype: 700-875-LTE01 (1.5.0) Serialnumber: R00070425 LTE Telekom.de

1. REX100 
2. ↓ 
3.  
4. ↓ 
5.  

Cloudserver : vpn2.myrex24.net
Accountname : guest
Name : ProjectLTE

CTM : no config available
Last config update : 03/04/16,13:28:07

CTM restart

Logging

User : admin(Administrator)

4.2.6. Change configuration with Configuration Transfer Manager (CTM)

If the REX 100 router has already gotten a configuration file, you will be able to transfer any new configuration changes to the router using the CTM. If the router has already been configured using the CTM and you click on "Save" in the "Device Administration" page after making changes to a configuration, the "Prepare for CTM" dialog box will appear.

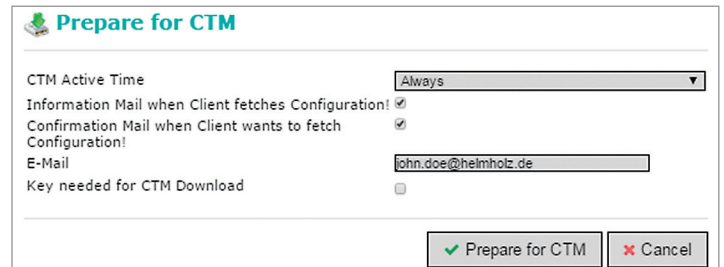

 **Prepare for CTM**

CTM Active Time

Information Mail when Client fetches Configuration!

Confirmation Mail when Client wants to fetch Configuration!

E-Mail

Key needed for CTM Download

Alternatively, you can also start transferring the configuration manually from the "Device Administration" of the myREX24 portal by clicking the floppy disk icon. If there is a configuration ready to be transferred using the CTM, the  icon will be shown in "Device Administration".

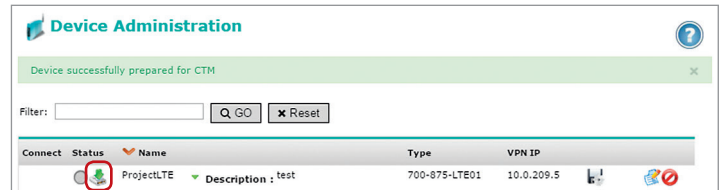

Note: In order to establish a VPN connection with the REX 100, please read Chapter 5, page 15.



Device Administration

Device successfully prepared for CTM

Filter:

Connect	Status	Name	Description	Type	VPN IP
		ProjectLTE	Description : test	700-875-LTE01	10.0.209.5

4.3 Transferring the configuration using a local LAN connection

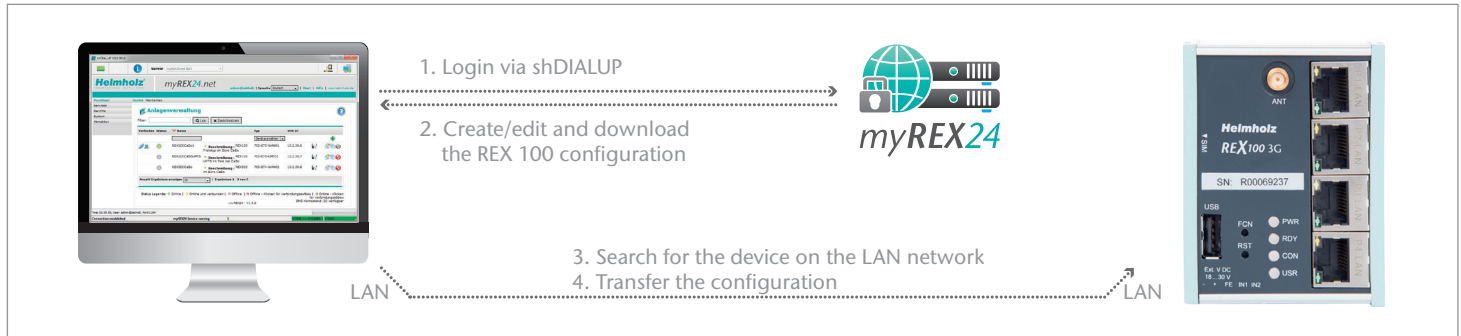

In order to be able to transfer the configuration through the LAN network, it must be possible to reach the REX 100 unit (the one being configured) on the same network on which the computer with the shDIALUP program is found.

- Connect your computer's LAN port (LAN card) to one of the REX 100 unit's LAN ports. Make sure to use a standard Cat5 patch cable to establish the direct connection between your computer and the router.
- In the myREX24 portal (shDIALUP) in Device Administration, select the option "Transfer configuration to the device".

After you have selected the corresponding PC-LAN network card in the device search menu, the search for locally connected REX routers is carried out automatically in the following dialogue.

The transfer will start if a device with the right serial number is found. Once the transfer is complete, the REX 100 router will start using the new configuration after being restarted.

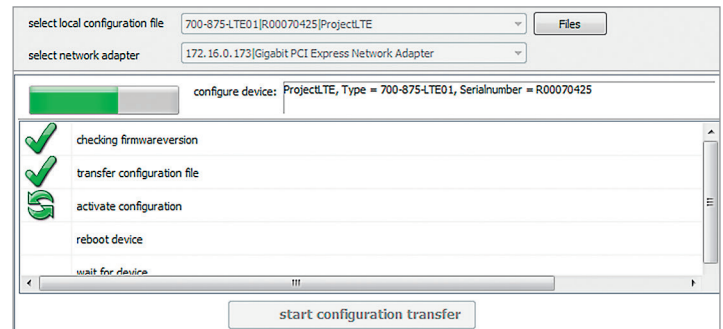
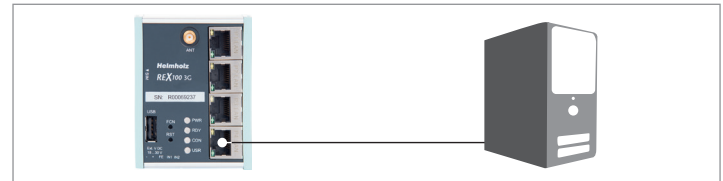

5. Establishing a VPN connection to your REX 100

Note: In order for the following steps to work, the REX router must have already been configured.

5.1 Establishing a VPN connection and transferring IP packages

After you log in successfully with shDIALUP, your online account will be opened. Logged-in REX routers will be indicated with a green circle.

If you now want to connect to an REX router, you can click on the "QuickConnect" button to establish a connection to your system.

In the "Connect Status" field, you are shown the REX "LAN IP" address on the system side (important, for example, for the "PG/PC interface", see chapter 6, page 16).

Once a connection to the REX 100 has been established, all the IP packets that are valid for the LAN network in the field will be forwarded.

To terminate the remote access connection, click on the "Disconnect" button.

The "Status Legend" provides more information on additional "statuses".

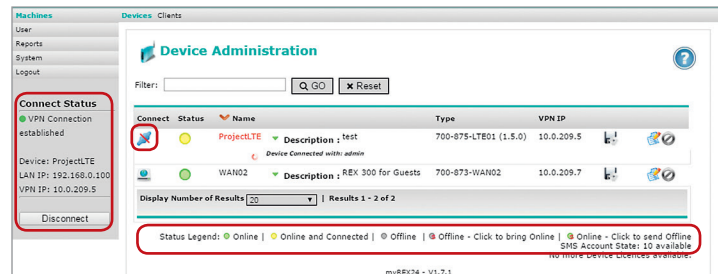
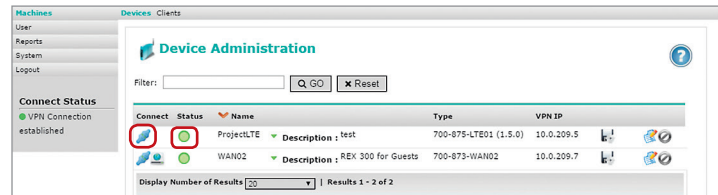

5.2 Tips and tricks

- If the connection to the myREX24 portal does not work on the first try, please install our "shCHECK" testing tool on a PC. This free program will check whether the ports needed to successfully establish a connection to the myREX24 portal are open. This test can be carried out both in the network from which a REX router is to create a connection to the Internet and from the Internet PC on which the shDIALUP dial-up software has been installed.
- In order to be able to establish a connection to the myREX24 server with shDIALUP, at least one of the TCP ports (80, 1194, or 443) required for the VPN tunnel must be open.
- The required outbound TPC address is 5.39.123.5

- Alternatively, you can also view the status of your machines with a direct invocation from your browser: <https://vpn2.myrex24.net>. Please use your shDIALUP access data to register. Following successful registration, device configurations can be adapted as needed and made available on the CTM. WEB2go sessions can also be opened if available.
- In the event that the provider interrupts the connection of your REX 100 router during GSM remote maintenance, this may have taken place for the following reasons, among others: incorrect user name/password, ports blocked by the provider or no more credit for prepaid SIM cards.

6. Remotely servicing an Ethernet PLC

Note: The integrated 4-port switch is suitable for 100 Mbps and full duplex operation and supports auto-crossover and auto-negotiation. No special PROFINET functions that are required for use in systems with PROFINET conformance class B or C are supported. Please note that the "P1" LAN interface is started delayed for technical reasons in the event of a device reset.

In order to be able to access an Ethernet PLC through a VPN connection, the "Use router" option must be enabled and correctly filled out in the PLC for the Ethernet port being used for remote servicing purposes.

The IP you need to enter under "Address" corresponds to the REX 100 unit's LAN IP address.

Note: The IP address of the PLC must lie within the address range of the LAN interface of the REX 100. If it should not be possible to activate the "Use router" option in your project, or if you want to reach an Ethernet device for which you cannot enter a gateway IP, please check the security settings in Device Administration of the myREX24 portal in the "Settings" tab.

The SNAT function should be enabled under "General Firewall Settings" so that you will be able to reach devices in which a gateway IP has not been entered. This function is always enabled in myREX24 configurations.

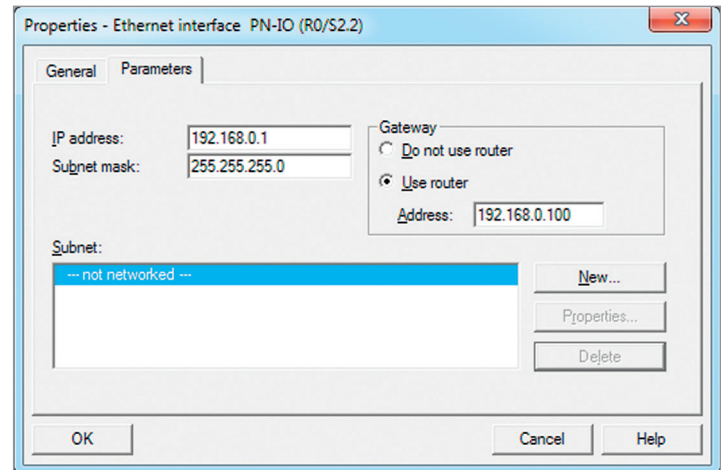

In order to be able to reach the PLC through the VPN tunnel, you will have to select the appropriate Open VPN adapter in the PG/PC interface. The virtual network connection responsible for this is the TAP Windows¹ Adapter V9.

Note: You can use either crossover or standard Ethernet cables to connect PLCs to the REX 100 unit.

The SIMATIC STEP 7² "Available Nodes" function is not supported by the software when using VPN connections.

As soon as a VPN connection to the REX 100 unit has been established (see chapter 5, page 15), you can start working with the PLC from the project (e.g., transferring a hardware project, monitoring variables, etc.).

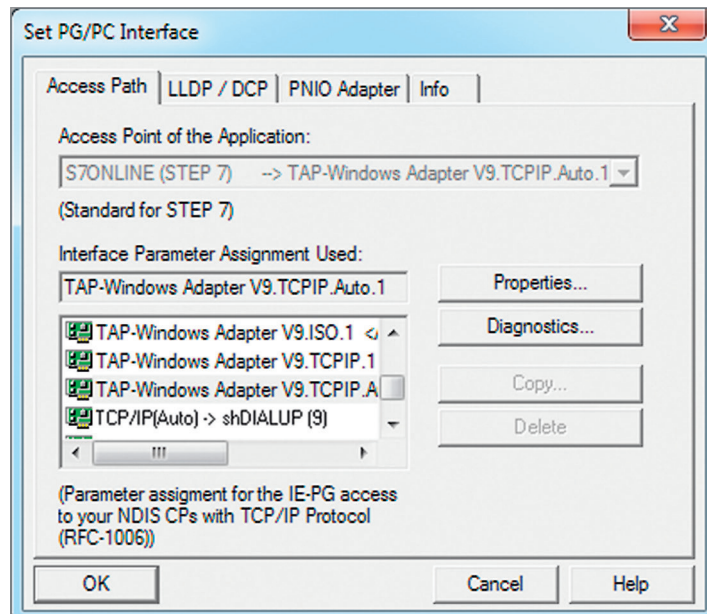

7. Description of LEDs and buttons

7.1 LED description

PWR	Indicator light for the power supply
RDY	Readiness indicator (this LED must show a solid light after a max. of 110 s)
CON	Off: There is no active Internet or VPN connection Solid light: Internet connection active or possible, but VPN connection inactive Rapid flashing (3 Hz): The router is attempting to establish a VPN connection Flashing (1.5 Hz): VPN connection active
USR	Solid light: When loading default settings, firmware files, or device configurations Flashing (1.5 Hz): A portal configuration was recognized on the USB stick (see FCN button, point 2.) Rapid flashing (3 Hz): A firmware file was recognized on the USB stick (see FCN button, point 2.)

7.2 Button description

FCN	<ol style="list-style-type: none">1. Function button used to manually establish a connection with the portal server (see screenshot on page 7)2. If the USR LED starts flashing, this means that you have ten seconds to press this button in order to load data from an inserted USB stick.
RST	Reset button for restarting the router

8. Restoring the REX 100 router to its default settings

In order to reset the REX 100 to the factory settings, the following steps are necessary:

- Apply a supply voltage (or press "RST") until the "PWR" LED lights up
- Wait until the RDY LED flashes
- Press the FCN button for approx. 10–15 seconds until the USR LED flashes orange
- After you release the "FCN" key, the REX 100 reboots and once again has the factory settings

Important: The IP address of the REX 100 LAN interface is reset to 192.168.0.100/24.

9. Load configuration/firmware update from USB stick

Note: Ensure that either only the firmware file or only the configuration file is found in the root directory of the USB stick. If you wish to update both the firmware and the configuration, carry out the following steps for each file individually.

To provide the REX 100 with a configuration or perform a firmware update from a USB stick, please carry out the following steps:

- The boot process of the device must be completed (PWR & RDY LEDs light up continuously)
- Don't change the file name and save this in the root directory of a standard FAT-formatted USB stick
- Insert the USB stick into the USB interface of the REX 100
- Once the USR LED starts flashing, you will have ten seconds to press the FCN button.
- The voltage supply should not be interrupted during the procedure.
- Once the USR LED lights up continuously, you can release the FCN button, at which point the data will be loaded from the USB stick
- The process is complete once the PWR and RDY LEDs light up again permanently.

Note: Once the configuration file has been successfully transferred, the file will automatically be renamed "Xmyrex24.mbn", making it impossible to accidentally reuse it a second time.

10. Technical data

	3G (700-875-UMT01)	LTE (700-875-LTE01)
Dimensions (D x W x H)	35 x 59 x 75 mm	35 x 59 x 75 mm
Weight	Approx. 270 g	Approx. 270 g
GSM modem	Quad-band GPRS/EDGE data interface	Multiband GSM/GPRS/WCDMA/LTE data interface
Antenna connection	SMA connector (external thread)	SMA connectors (external thread)
Type of SIM card	Standard SIM, 1.8 V/3 V	Standard SIM, 1.8 V/3 V
GSM frequency bands (MHz)	GSM/GPRS/EDGE: 850, 900, 1800, 1900	GSM 900, DCS1800
UMTS/HSPA frequency bands (MHz)	UMTS/HSPA: 800/850, 900, AWS 1700, 1900, 2100 class 1	B5(850), B8 (900), B1 (2100)
LTE frequency bands (MHz)	–	B20 (800), B3 (1800), B7 (2600)
Transmit power	Class 1, E2, 3, 4	Class 1, E2, 3, 4
Data transfer rates	HSPA+ (upload: 5.76 Mbps download: 21.0 Mbps)	HSPA+ (upload 5.76 Mbps download 42.0 Mbps); LTE (upload 50 Mbps download 100 Mbps)
Number of inputs/switching point	2/24 V (DC), as per DIN EN 61131-2 Type 2	2/24 V (DC), as per DIN EN 61131-2 Type 2
Router functions	Firewall, NAT/PAT, SMS wake-up	Firewall, NAT/PAT, SMS wake-up
VPN	OpenVPN	OpenVPN
Interfaces	Four 10/100 Mbps LAN ports USB 2.0 Type A port	Four 10/100 Mbps LAN ports USB 2.0 Type A port
Voltage	DC 24 V (18 ... 30 VDC, SELV and limited energy circuit)	DC 24 V (18 ... 30 VDC, SELV and limited energy circuit)
Current draw	Max. 250 mA with DC 24 V	Max. 250 mA with DC 24 V
Ambient temperature	-40 °C ... +75 °C	-40 °C ... +75 °C
Transport and storage temperature	-40 °C ... +85 °C	-40 °C ... +85 °C
Humidity	0 to 95 %, non-condensing	0 to 95 %, non-condensing
Location of use	Dry location	Dry location
Protection rating	IP20	IP20
Certifications	CE, UL	CE, UL

10.1 UL

	3G (700-875-UMT01)	LTE (700-875-LTE01)
Pollution degree	2	2
Altitude	Up to 2000 m	Up to 2000 m
Temperature cable rating	87 °C	87 °C

Note

Our products contain, among others, open source software. This software is subject to the applicable licensing conditions. We will send you the appropriate licensing conditions, including a copy of the complete licensing text, together with the product. These are also available in our download area of the respective product under www.helmholz.com.

We also offer to send you or any third party the complete source code of the applicable open source software as a DVD upon request for a contribution towards costs of 10.00 Euro. This offer is valid for a period of three years as of the delivery of the product.

The contents of this Quick Start Guide have been checked by us so as to ensure that they match the hardware and software described. However, we assume no liability for any existing differences, as these cannot be fully ruled out.

The information in this Quick Start Guide is, however, updated on a regular basis. When using your purchased products, please make sure to use the latest version of this Quick Start Guide, which can be viewed and downloaded on the Internet at www.helmholz.com. Our customers are important to us. We are pleased to receive suggestions for improvement and new impulses.

1) Windows is a registered trademark of the Microsoft Corporation.

2) SIMATIC and STEP 7 are registered trademarks of Siemens AG.