



NETLink

Ethernet Gateways for MPI/PPI/PROFIBUS

Manual for all NETLink® Ethernet versions:

700-881-MPI21

700-882-MPI21

700-884-MPI21

Edition 3 / 16.02.2021 / ab FW 2.58

Order number of manual: 900-88X-MPI21/en

All rights are reserved, including those of translation, reprinting, and reproduction of this manual, or parts thereof. No part of this manual may be reproduced, processed, copied, or transmitted in any way whatsoever (photocopy, microfilm, or other method) without the express written permission of Helmholtz GmbH & Co.KG, not even for use as training material, or using electronic systems. All rights reserved in the case of a patent grant or registration of a utility model or design.

Copyright © 2009 by

Helmholtz GmbH & Co.KG

Hannberger Weg 2, 91091 Grossenseebach, Germany

Note:

We have checked the content of this manual for conformity with the hardware and software described. Nevertheless, because deviations cannot be ruled out, we cannot accept any liability for complete conformity. The information in this manual is regularly updated. When using purchased products, please heed the latest version of the manual, which can be viewed in the Internet at www.helmholz.com, from where it can also be downloaded.

Our customers are important to us. We are always glad to receive suggestions for improvement and ideas.

Revision history of this document:

Edition	Date	Revision
1	16.06.2012	Summary of all Ethernet variants
2	16.03.2015	NETLink Switch deleted; Troubleshooting supplements
3	16.02.2021	General updates

Contents

1	Safety Information	7
1.1	General	7
1.2	Restriction of access	8
1.3	Information for the user	8
1.4	Use as intended	8
1.5	Avoiding use not as intended!	8
2	Installation and mounting	9
2.1	Mounting orientation	9
2.2	Minimum spacing	9
2.3	Installing the module	9
2.3.1	NETLink® PRO PoE and NETLink® WLAN	9
2.3.2	NETLink® PRO Compact	9
3	Overview of the System	10
3.1	Application and functional description	10
3.1.1	NETLink® PRO Poe and NETLink® WLAN	10
3.1.2	NETLink® PRO Compact	11
3.2	Connections	12
3.2.1	NETLink® PRO PoE and NETLink® WLAN	12
3.2.2	NETLink® PRO Compact	12
3.3	LED-Indicators	12
3.3.1	LEDs on the RJ45 network jack (all NETLink® versions)	13
3.3.2	General LED Indications and Connectors	13
3.3.3	LED-displays on the NETLink® PRO Compact	15
3.4	Included in Delivery	15
3.5	Accessories	15
3.5.1	Manuals	15
3.5.2	Software	15
3.5.3	Other accessories	15
3.5.4	WLAN antenna and antenna cable	16
4	Installation of the driver software	17
4.1	Introduction	17
4.2	System requirements	17
4.3	Running the installation setup	17
4.3.1	Adding the interface to the PG/PC interface	18
4.3.2	Selecting the required interface parameterization	20
5	Configuration via the NETLink-S7-NET Driver	21
5.1	Bus settings	21

5.1.1	MPI	22
5.1.2	PROFIBUS configuration	23
5.1.3	PPI configuration	26
5.2	Local connection (TCP parameterization)	26
5.2.1	Creating a station	27
5.2.2	Setting TCP parameters	29
5.2.3	Operation without the DHCP	30
5.2.4	DHCP	31
5.2.5	Additional features	31
5.3	Options of the driver	32
5.3.1	Language setting of the display elements	32
5.3.2	Version information	32
5.4	Diagnostics	33
5.4.1	Bus members	33
5.4.2	Bus parameters	33
6	The Tool: 'NETLink® PRO Family Configuration'	35
7	Possibilities of the Web Interface	36
7.1	Home Page	36
7.2	Setting up access	36
7.3	Status Page	37
7.4	Configuration page	37
7.5	Security page	38
7.6	Observing variables	39
7.7	NETLink® WLAN configuration	39
7.7.1	NETLink® WLAN in the infrastructure mode (AP)	39
7.7.2	NETLink® WLAN in the ad hoc mode	40
7.7.3	Connection establishment PC to NETLink® WLAN in the unencrypted ad hoc mode	40
7.7.4	Connection establishment PC to NETLink® WLAN in the encoded ad hoc mode	42
8	RFC1006-Function (S7-TCP/IP)	46
8.1	CPU Addressing with Rack/Slot and TSAP	46
9	Bus Parameters in Single Master Operation	48
9.1	Storing specified bus parameters	48
9.2	Addressing with Routing over RFC	49
9.2.1	RFC Multicomputing with TSAP	50
9.2.2	RFC Routing over CP with TSAP	50
10	Troubleshooting	52
11	Appendix	56

11.1	General technical Data	56
11.1.1	Technical Data NETLink® PRO PoE	56
11.1.2	Technical Data NETLink® WLAN	56
11.1.3	Technical Data NETLink® PRO Compact	57
11.2	Pin assignments	57
11.2.1	MPI/PROFIBUS interface pin assignments	57
11.2.2	Assignment of the Ethernet interface (host interface)	57
11.2.3	Power supply socket	57
11.3	Further documentation	58
11.3.1	Information in the internet	58
11.3.2	Further information	58
11.3.3	Address conversion table	59
12	Glossary	60

1 Safety Information

For your own safety and for the safety of others, always heed the safety information given here. The safety information indicates possible hazards and provides information about how you can avoid hazardous situations.

The following symbols are used in this manual.



Caution, indicates hazards and sources of error



Gives information



Hazard, general or specific



Danger of electric shock

1.1 General

A NETLink® Gateway is only used as part of a complete system.



The operator of a machine system is responsible for observing all safety and accident prevention regulations applicable to the application in question.



During configuration, safety and accident prevention rules specific to the application must be observed.



Emergency OFF facilities according to EN 60204 / IEC 204 must remain active in all modes of the machine system. The system must not enter an undefined restart.



Faults occurring in the machine system that can cause damage to property or injury to persons must be prevented by additional external equipment. Such equipment must also ensure entry into a safe state in the event of a fault. Such equipment includes electromechanical safety buttons, mechanical interlocks, etc. (see EN 954-1, risk assessment).



Never execute or initiate safety-related functions using an operator terminal.



Only authorized persons must have access to the modules!

1.2 Restriction of access

The modules are open equipment and must only be installed in electrical equipment rooms, cabinets, or housings. Access to the electrical equipment rooms, barriers, or housings must only be possible using a tool or key and only permitted to personnel having received instruction or authorization.

1.3 Information for the user

This manual is addressed to anyone wishing to configure, use, or install a NETLink® Gateway.



During configuration, safety and accident prevention rules specific to the application must be observed.

The manual tells the user how to operate the NETLink® and explains the signaling functions. It provides the installing technician with all the necessary data.

The NETLink® Gateways are exclusively for use with a S7-200 and S7-300/S7-400 programmable controller from Siemens.

A NETLink® is for use within a complete system only. For that reason, the configuring engineer, user, and installing technician must observe the standards, safety and accident prevention rules applicable in the particular application. The operator of the automation system is responsible for observing these rules.

1.4 Use as intended

These NETLink® Gateways must only be used as a communication and signaling system as described in the manual.

1.5 Avoiding use not as intended!

Safety-related functions must not be controlled via a NETLink® alone. Make sure in the software that uncontrolled restarts cannot occur.



Make sure in the software that uncontrolled restarts cannot occur.



Before you start installation work, all system components must be disconnected from their power source.

2 Installation and mounting

Installation and mounting must be carried out in accordance with VDE 0100 / IEC 364. As this is an IP20 module, it must be installed in a cabinet.

A maximum ambient temperature of 60 °C must be ensured for reliable operation.

2.1 Mounting orientation

All NETLink® can be installed in any orientation.

2.2 Minimum spacing

By maintaining minimum spacings

- then NETLink® Gateways can be inserted and removed without having to remove other system components.
- there is sufficient space to connect existing interfaces and other contacts using standard commercial type accessories.
- there is room for any necessary cable routing.

For a NETLink® PRO PoE, NETLink® Switch and a NETLink® WLAN a minimum clearance of 60 mm must be left above and below and 10 mm at the sides.

2.3 Installing the module

2.3.1 NETLink® PRO PoE and NETLink® WLAN

A wall/DIN rail bracket is available as an accessory for mounting on flat surfaces or on DIN rails.

The accessories available are listed in Section 3.5, together with the corresponding order numbers.

2.3.2 NETLink® PRO Compact

The NETLink® PRO Compact is plugged directly into the SUB D female connector of the PROFIBUS station instead of the standard PROFIBUS device connector. It is fixed using the permanently integrated hexagon-head housing screws and therefore makes permanent contact.

Further bus nodes for diagnostic devices can be connected to the integrated PG female connector.

Only CAT5-TCP cables with an RJ45 connector can be connected to the NETLink® PRO Compact housing. No further outlets, for example, PROFIBUS cable, can be installed on the device. Therefore no termination is possible on the connector housing and the "ON/OFF" switch for this is not been incorporated.

3 Overview of the System

3.1 Application and functional description

The NETLink® is a gateway between a TCP network and an MPI, PPI, or PROFIBUS network.

Two protocols are available on the TCP side for the exchange of user data with the automation system:

- one is a proprietary protocol that is used to connect to the proprietary NETLink-S7-NET driver, and
- the other is the S7-TCP/IP protocol often used by visualization system manufacturers which is known as 'RFC1006' or 'ISO on top of TCP'.

Up to 16 TCP connections (10 Mbps or 100 Mbps) and up to 32 MPI/PPROFIBUS connections (9.6 Kbps to 12 Mbps) can be used simultaneously.

The TCP/IP end of the NETLink® is electrically isolated from the MPI/PPI/PROFIBUS.

On both the TCP and the field bus sides, the baud rate used can be determined automatically (auto negotiation resp. auto baud).

!
The TCP/IP communication is not encoded to the extent that no direct IP Internet tele servicing should take place via a NETLink® gateway.

Internet tele servicing with NETLink® products should only take place through additional encoding mechanisms and the usual security criteria. The usual VPN technology (Virtual Private Network) is suitable for this purpose. Further components are necessary to incorporate a NETLink® gateway into such a virtual tunnel.

3.1.1 NETLink® PRO Poe and NETLink® WLAN

The connecting cable used to link the NETLink® Gateway with the programmable controller is 1.2 meters long and active. Because it is active, no spur lines are required which could interfere with the bus.

These NETLink® devices can draw the necessary power from either the bus interface of the programmable controller or via an external power supply.

In addition to the wired TCP/IP connectivity the NETLink® WLAN has a built-in Wi-Fi module. The adapter can establish a connection to an access point via the so called "Infrastructure Mode". In addition it is possible to establish a direct connection to a PG/PC using the so called "AdHoc Mode". NETLink® WLAN supports WLAN standards 802.11 b/g. Therefore, data rates of up to 54 Mbps are possible.

The NETLink® PRO PoE is a Powered Device (PD) according to the IEEE 802.3af (POE) and IEEE 802.3at (POE+) standards. This is the generally accepted term for technology that supplies devices with power via a commercially available 8 wire RJ 45 Ethernet cable. This standardisation ensures worldwide compatibility and high flexibility when used in PoE installations; for example, that is affected by neither transmission capacity nor range (even in

Added feature 'Power over Ethernet' according to the IEEE 802.3af standard

existing networks). The power supply is assured by the Power Source Equipment (PSE). This type of switch, hub or power injector supports the Resistive Power Discovery which ensures that the power delivered via the LAN is only activated when a compatible end-device such as NETLink® PRO PoE has been detected, the 48 V supply is automatically blocked when non-PoE Ethernet devices are detected. In this way both conventional and PoE-compatible devices can be used together in connection with the energy supply devices described above.

As can be seen in the pin assignment of the NETLink® PRO PoE network connector, the energy supply is fed via the Spare-Pair wire pairs 4/5 and 7/8, ensuring that the 4 remaining data transfer wires are not affected. In addition, dependent on the PSE unit in use, the existing wiring can be used for distributing power. Using the Phantom Power the power supply is ensured through its superimposition on the data signals. The NETLink® PRO PoE automatically recognises the current technique and can therefore be used with all types of PSE.

In addition the specification mandates that the PD can be supplied over up to 100 metres of cable without a repeater. In order to ensure that the distribution resistance (and the resulting power loss) is minimised to the greatest possible extent, excessive use of plug/socket extension elements should be avoided where possible.

The connection between PSE and PD can be either a straight or a cross-over cable. Using special input switching, the NETLink® PRO PoE recognises the actual polarity.

The external feed or the bus interface of the automation system have priority for the external 24 V supply to the NETLink® PRO PoE. If one of these fails, PoE is used as a reserve. Due to the internal switchover the device automatically carries out a reset.

Further important concepts behind Power over Ethernet are described in the glossary (Section 12).

3.1.2 NETLink® PRO Compact

The NETLink® PRO Compact has the shape of a PROFIBUS connector with a PG female connector and it is plugged directly into the MPI/PPI/PROFIBUS interface of the automation system. Because it is active, no spur line is created that could interfere with the bus. The TCP/IP end of the NETLink® PRO Compact is electrically isolated from the MPI/PPI/PROFIBUS.

On both the TCP and the field bus sides, the baud rate used can be determined automatically (auto negotiation or auto baud)

The NETLink® PRO Compact can draw the necessary power supply either from the bus interface of the programmable controller or via an external power supply.

The use of the NETLink-S7-NET driver makes it possible to use the NETLink® Gateways as the following at the PC end

- Programming adapter, or
- Operator control and monitoring unit

The RFC1006 interface also enables you to use third-party software that supports this protocol to communicate with S7-200/S7-300 and S7-400 systems.

A NETLink® can generally be connected to the PC via a switch, hub or directly via LAN cable.

3.2 Connections

All NETLink® devices have the following connections:

- RJ45 female connector for connecting the supplied standard CAT5-TCP cross-over cable. The automatic interface detection “Auto - (MDI) X” means that switches and computer direct connections can be used with this cable type. A separate converter is not required.
- Power supply socket for 24 V DC power supply. This power supply option can be used optional (except of the NETLink® switch), if the used programmable controller does not provide any or only insufficient power on the bus connector.

3.2.1 NETLink® PRO PoE and NETLink® WLAN

These versions included a bus connector with programming unit female connector, switchable terminating resistor, and 1.2 m connecting cable. This is an ‘active cable.’ This means there is no spur line, thus avoiding interference on the bus at high baud rates. The programming unit female connector of the bus connector allows further bus nodes to be plugged in. The terminating resistor must be inserted (ON) if these NETLink® devices are plugged in at the start or end of a bus segment. If this is not the case, the switch must be in the OFF position.

- The NETLink® WLAN contains in addition a SMA socket for connection to a customary WLAN antenna (for accessories, see Section 3.5).
- The NETLink® PRO PoE can also be supplied via an Powered Ethernet switch/router, which may deliver the 48 volt supply to the RJ45 connector. Further information about Power over Ethernet is explained in Section 3.1.1.

3.2.2 NETLink® PRO Compact

The NETLink® PRO Compact is completely embedded in a bus connector. This compact device represents also an ‘active cable’, which means there is no spur line which avoids interference with higher baud rates.

3.3 LED-Indicators

All NETLink® Gateways come with several bi-colored LEDs to indicate the operating status.



All NETLink have the IP address 192.168.4.49 on delivery from the factory.



Lights or blinks only the yellow LED, then the respective port is set to 10 Mbps.

3.3.1 LEDs on the RJ45 network jack (all NETLink® versions)

The two LEDs which are located on each RJ45 female connector indicate by their status the current state of the TCP network:

LINK LED (green)		ACTIVE LED (yellow)	
Status	Description	Status	Description
OFF	Not connected	OFF	No activity on the network
ON	Connected	ON	Activity on the network
BLINK		BLINK	Activity on the network

3.3.2 General LED Indications and Connectors

The three LEDs (two two-colored LEDs) on the top of the NETLink® indicates the operating status of the device itself:

LED status versus operating status	Power LED (green)	Active LED (green)	Active LED (red)	Connect LED (green)	Connect LED (red)
Seeking for network partner and TCP configuration	BLINK				
Ready for operation	ON				
Expects MPI / PPI / PROFIBUS parameters for login	ON	BLINK			
Actively logged on to the MPI/PPI/PROFIBUS	ON	ON			
Active connection to an automation system	ON	ON		ON	
Data exchange with an automation system	ON	ON		BLINK	
Transferring firmware update	BLINK		BLINK		BLINK
Storing firmware update	ON		ON		ON
Bus side exception error	ON				BLINK
Programming unit/PC side exception error	ON		BLINK		

LEDs and connectors on the NETLink® PRO PoE:

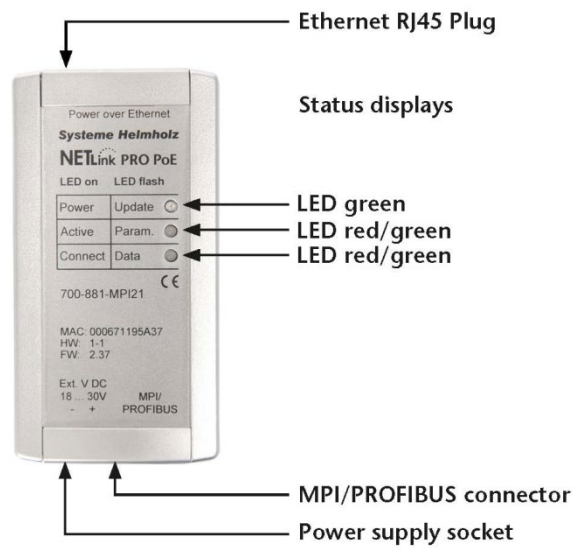

The NETLink® WLAN has two extra LEDs on the top of the case, which indicate the operating status of the wireless connection:

DIAG LED (yellow)		ACTIVE LED (green)	
Status	Description	Status	Description
OFF	No Errors (WLAN)	OFF	No WLAN connection
ON	Wi-Fi module damaged	ON/BLINK	Connection established
BLINK	Read/write Configuration	BLINK	Try to attempt a WLAN connection

LEDs and connectors on the NETLink® WLAN:

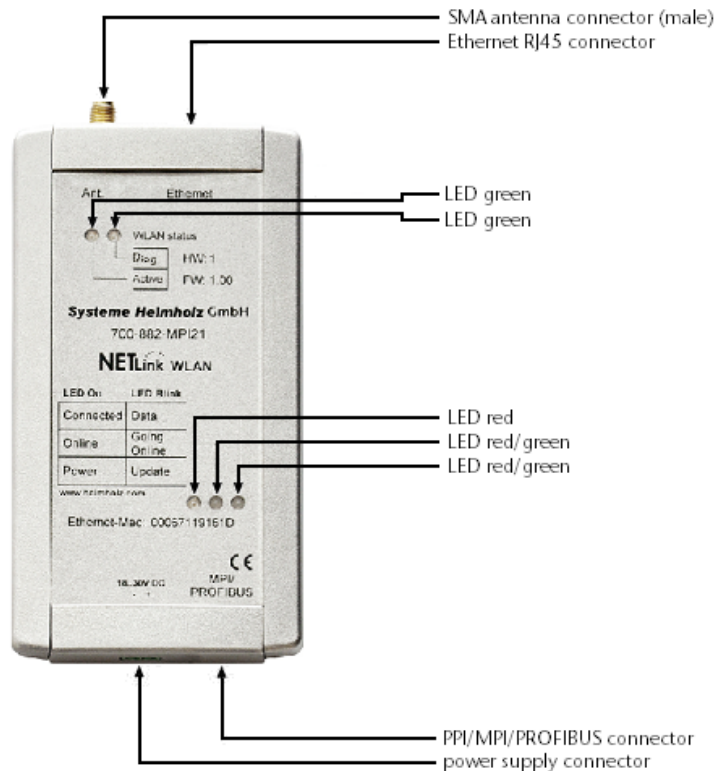

3.3.3 LED-displays on the NETLink® PRO Compact

The NETLink® PRO Compact has two multi-colored LEDs. These are located on the front of the housing behind a white inspection window.

LED status for operating status	Power LED (blue)	Bus LED (orange)	Active LED (green)	Bus LED (red)
Seeking for network partner and TCP configuration	BLINK			
Ready for operation	ON			
Expects MPI/PPI/PROFIBUS parameters for login	ON	BLINK		
Actively logged on to the MPI/PPI/PROFIBUS	ON		ON	
Data exchange with a programmable controller	ON		BLINK	
Transferring firmware update	ON			BLINK



All NETLink have the IP address 192.168.4.49 on delivery from the factory.

3.4 Included in Delivery

The following is delivered with each NETLink® device:

- NETLink® ready for operation
- CAT5 TCP cable (cross-over) with a length of 3 meters
- label with QR codes and relevant download links

3.5 Accessories

3.5.1 Manuals

The current version is available for download at www.helmholz.de.

3.5.2 Software

With the help of our freely available diagnostics and update software SHTools, you can, for example, carry out firmware updates yourself. In order to ensure the complete functional scope of your NETLink® adapter, we recommend that you regularly update your devices. The most recent version is available for download at www.helmholz.de.

3.5.3 Other accessories

DIN rail bracket for NETLink® WLAN 700-751-HSH10

DIN rail bracket for NETLink® PRO PoE 700-751-HSH01

The DIN rail bracket is for mounting the NETLink® on DIN rails. It can also be used as a wall bracket for mounting on flat surfaces.

The DIN rail bracket and NETLink® can be separated without the use of tools.

Mains power adapter 700-751-SNT01

Input: AC 100-240 V /Output: DC 24 V

You can find additional technical data at www.helmholz.de

Active PROFIBUS plug cable 3m 700-901-4BD00

3.5.4 WLAN antenna and antenna cable

2,4 GHz 5 dBi magnetic base antenna

(With 1m cable) 700-889-ANT01

2,4 GHz 8 dBi Omni antenna

(Required cable see below) 700-889-ANT02

2,4 GHz 8 dBi Panel antenna

(Required cable see below) 700-889-ANT03

Antenna cable, 3 m; 1,7 dB Ø 2,5 mm 700-889-ANK01

Antenna cable, 5 m; 2,8 dB Ø 2,5 mm 700-889-ANK02

Antenna cable, 6 m; 1,4 dB Ø 10 mm 700-889-ANK03

Antenna cable, 10 m; 2,3 dB Ø 10 mm 700-889-ANK04

4 Installation of the driver software

With installation of the NETLink-S7-NET driver for NETLink® Gateways, it is easy to access controllers with a MPI/PPI/PROFIBUS interface from the PC via TCP/IP.

4.1 Introduction

The NETLink-S7-NET driver is inserted in the PG/PC interface of an existing Simatic application and can then be used from most Simatic engineering tools (STEP7, ProTool, WinCC, etc.).

Access is possible to any controllers of the Simatic S7-200, S7-300, or S7-400 series via a NETLink® Gateway.

4.2 System requirements

A PC with a 32/64 Bit Microsoft operating system with administrative rights is required for the installation and operation of the current NETLink-S7-NET driver on the PG side. The functionality has been successfully tested with Windows XP/2003R2/7/2008R2/8.1/2012 R2/10.

A further requirement is the existence of a Simatic engineering tool, which ensures that the PG/PC interface is installed on the computer.

The most recent driver version was tested with:

Siemens TIA Portal from V13 and higher

SIMATIC Manager from version 5.5 and higher

and STEP7 Micro/Win as of version 4.0.

Installation under Windows 98/ME/NT operating systems is possible but is not supported by the technical support team of Helmholtz GmbH & Co.KG. Please pay attention to the requirements of the Simatic package used.

A functioning network link using TCP/IP must have been set up on the PCs that are used. The network configuration of the PC must be known. Commercially network cards and, for the connection, cross-over- or 1:1 (straight) cables may be used.

The integrated auto-negotiation function automatically negotiates the TCP/IP transmission speed between the stations. In this way, the best performance is achieved in a local 100 Mbps network. Status operation will be slowed down if older 10 Mbps network cards and hubs are used.

4.3 Running the installation setup

If necessary, you can download the latest NETLink-S7-NET driver from our homepage (<http://www.helmholtz.de>).

Please note that for installation you have to log on as an administrator under the 32-bit Windows operating systems because the setup program has to make entries in the Windows registry.



Administration rights are required for installation.

We also recommend right-clicking on the setup program icon and selecting: "Execute as administrator"

When installing the program on Windows 7 operating systems, make sure to not only log in with the Administrator account, but to also run the program setup file using the “Run as administrator” option!

For more detailed information, please refer to the relevant NET-Link Quick Start Guide.

4.3.1 Adding the interface to the PG/PC interface

After initial installation, the new interface parameter set ‘NET-Link-S7-NET’ has to be set up. Administrator rights are necessary for this.

Start the program module 'Set PG/PC Interface' with the Control Panel of your Windows PC. When the 'Select...' button is displayed under Add/remove interfaces, click it.



This installation step is not needed in Windows 7 operating systems. If you are using a computer with Windows 7, please skip ahead to the next section.

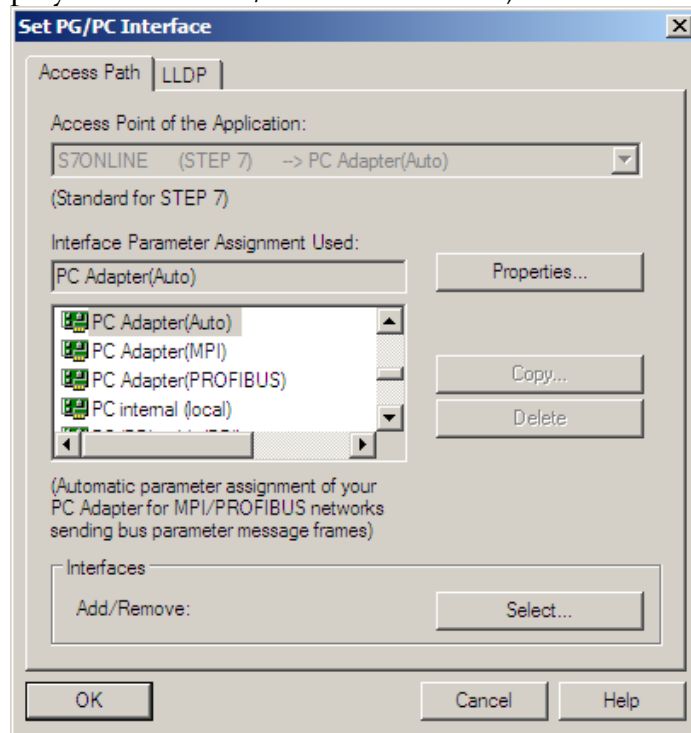

This opens the *'Install/uninstall interface'* dialog box.

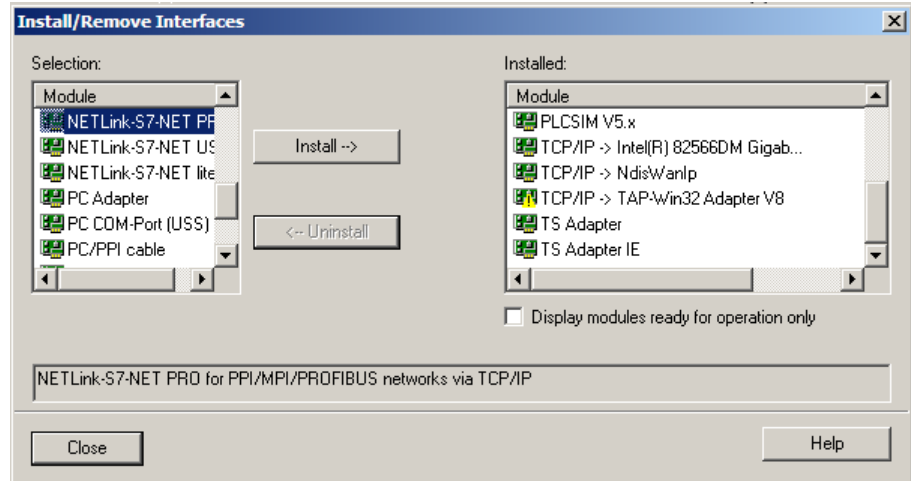

After you have selected the entry *'NETLink-S7-NET PRO family'* from the left-hand list, click the *'Install-->'* button.

The *'NETLink-S7-NET PRO'* has now been included in the selection list so that it is available for selection in future.

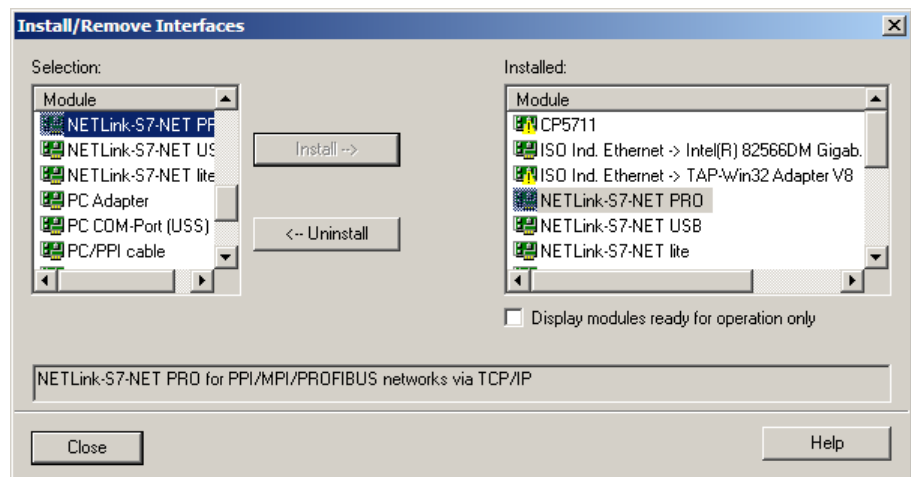

The access path in the *'Set PG/PC Interface'* dialog box is set when this window is closed.

4.3.2 Selecting the required interface parameterization

The selection list for the interface parameter sets now contains an additional three items for NETLink® PRO Family.

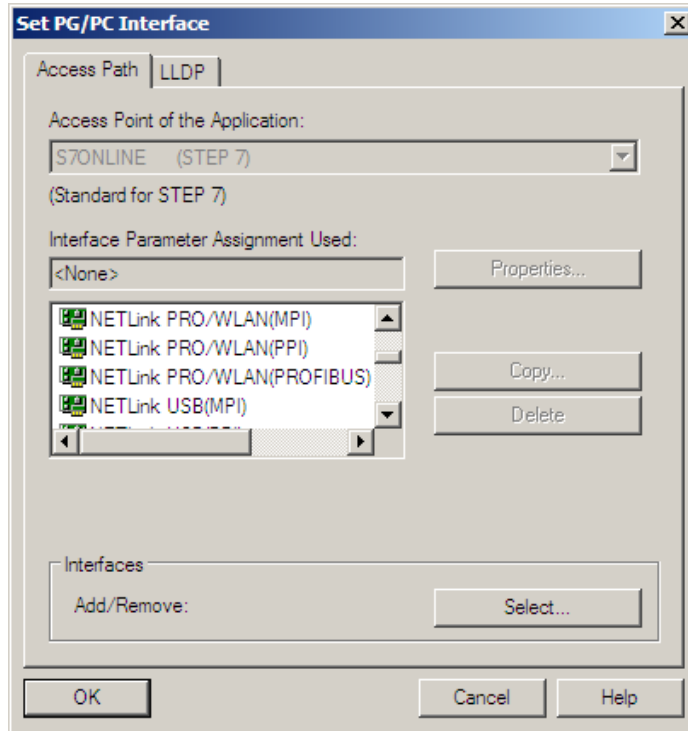

All relevant settings of a NETLink-S7-NET driver can be made via the "Properties" access field. With the button 'Diagnostics...' it is possible to show the nodes connected to the bus and the parameters the bus is working with. These fields are explained in Section 5.

5 Configuration via the NETLink-S7-NET Driver

Once a NETLink® PRO Family has been selected in the *'Set PG/PC Interface'* window, it is possible to specify this access path more precisely with the *'Properties...'* button.

With the functionality behind the button *'Diagnostics...'*, which is visible when a NETLink® PRO Family is selected, it is possible to read the bus configuration and scan connected nodes.

The properties of the access NETLink® PRO Family are divided into three subareas:

- **Bus settings**
here it is possible to state the bus configuration (e.g. station address) with which the NETLink® Switch will enter the bus system (Section 5.1).
- **Local connection (TCP configuration)**
Here, you set the IP address via which the required connection with the programmable controller will be established (Section 5.2).
The NETLink® Switch hardware can also be parameterized in this window.
- **Options**
Here it is possible to change the language of the NETLink-S7-NET driver and to read out the version information of the driver (Section 5.3).

Two functionalities are implemented for diagnostics at the connected bus:

- **Bus members**
a list of all active and passive nodes connected to the bus will be displayed. By request the order numbers (MLFBs) will be displayed also if this functionality is available by the nodes (Section 5.4.1).
- **Bus parameters**
If possible, a list of all available bus parameters will be displayed (Section 5.4.2).

5.1 Bus settings

The NETLink® Gateway can be operated on three different bus systems: MPI, PPI, and PROFIBUS.

From the NETLink® Gateway user's viewpoint, the three bus systems only differentiates by the transmission rates that can be selected and the additional options which are explained here.

The bus configuration is passed to the NETLink® during the runtime of the NETLink-S7-NET driver and is not stored in the device.

It is possible to use NETLink® without providing bus-related information. In this case, NETLink® will independently attempt to receive the transmission rates and the bus parameters from a master CPU, and can then be operated without resetting the NETLink-

S7-NET driver in various automation systems, possibly with different transmission speeds.

This auto-baud function is only supported when the '*Cyclical distribution of the bus parameters*' is activated in the involved automation system. This function is not available in S7-200 systems in general.

5.1.1 MPI

The MPI configuration contains station and network-related settings.

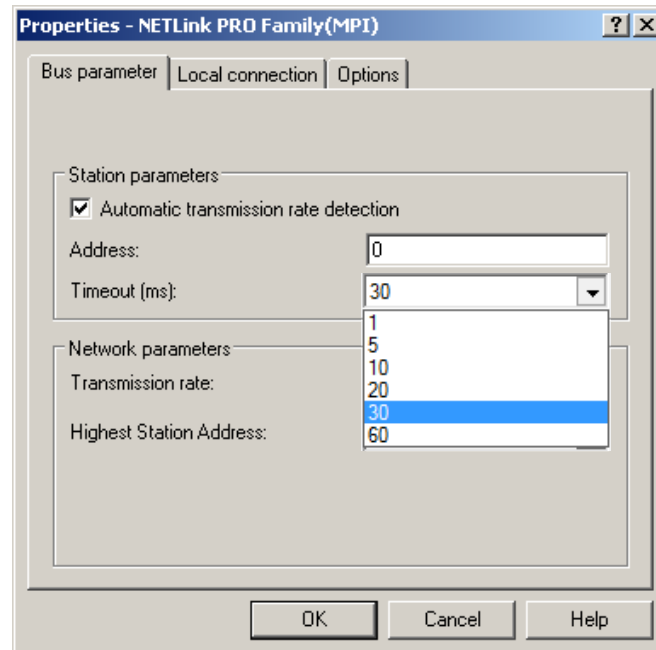

The most important setting concerning bus configuration is assignment of the station address. This refers to the address the NETLink® will have on the bus when it goes online.

The station address can have any value from '0' and '126' if the selected address is lower than or equal to the highest station address (HSA).

Example: HSA = 31

Any value between '0' and '31' can be specified for the station address if this address does not yet exist on the bus.

The local timeout of the NETLink-S7-NET driver can be parameterized in the station-related settings. If the driver does not receive a response to a request within the set timeout, a communication error is signaled to the Simatic application.

The network settings can be adapted manually if the checkmark next to "*Automatic Baud Rate Detection*" is removed. This is usually only necessary if the NETLink® fails to sign onto the bus system automatically (can happen with passive bus participant).



Enabling the “Automatic transmission rate detection” option will make connections take a little longer to initialize, since it will make it necessary to find out what the corresponding online parameters are. This function may not work reliably with slow bit rates (e.g., 19.2 kbps) and global data communications.

Some older Siemens CPUs do not support the auto baud function on the MPI. PPI systems do not usually support this function either. In such cases, the network-related parameters should be adapted manually.

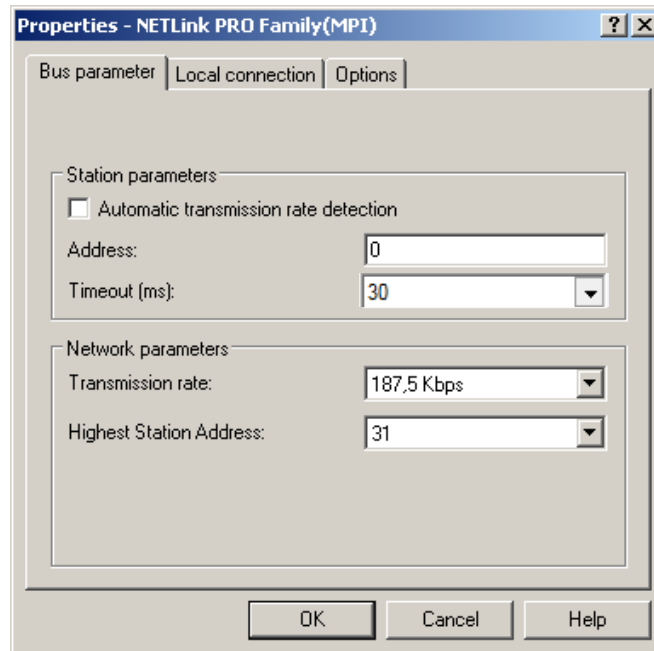

The transmission speed and the HSA of the PLC being addressed must be known and identical to all connected bus nodes.

It is also possible that the auto baud function may not function reliably at transmission rates slower than or equal to 19.2 Kbps or with increased use of communication via global data exchange, because the relevant frame is transmitted more irregularly by the CPUs. In such cases it may be advantageous to assign the bus parameters manually.

5.1.2 PROFIBUS configuration

Basically, the same applies to PROFIBUS configuration as to MPI configuration. However, the network-related parameters are more extensive.

In addition to the parameters transmission rate and highest station address mentioned in Section 5.1.1, PROFIBUS also has parameter field for selecting the bus profile and bus parameters.

If the NETLink® Gateway is the only active station on the PROFIBUS, it operates in so-called single-master mode, i.e. it generates the token cycle with the set bus parameters.

If the bus speed on the PROFIBUS is set to a value less than 187.5 Kbps, please remember that it may take up to half a minute for the bus parameters to be recognized.

In this case, the timeout value should be increased correspondingly.

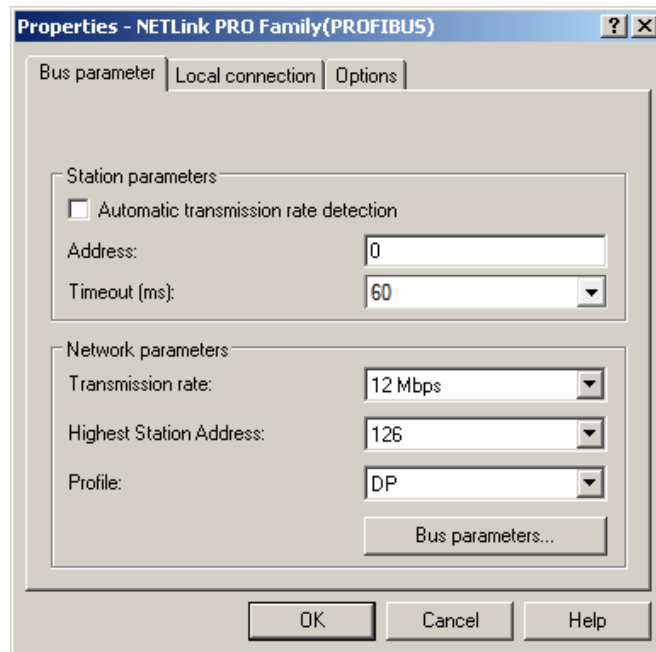

Profile:

- Under PROFIBUS, there are usually the profiles *DP*, *Standard* und *User defined*.
- The profile must be selected that is already used in the programmable controller.

Bus parameters:

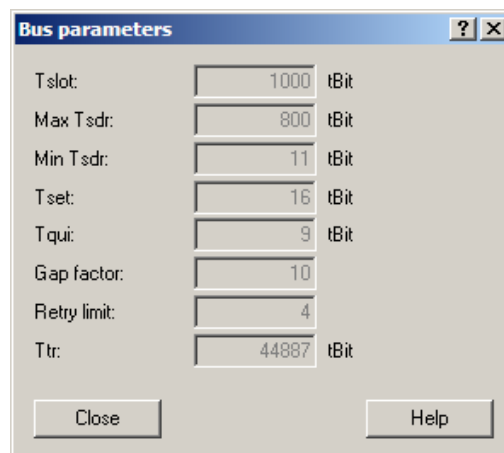

- Unlike the MPI bus profile, the bus parameters for PROFIBUS are not constant and change with the type and number of PROFIBUS stations used.
- Always set the PROFIBUS parameters that are set in the currently used programmable controller (see current STEP7 project).

Whenever an active CPU is involved, which transmits the profibus parameters, we recommend activating the "Automatic transmission rate detection".

In this way you avoid the laborious steps involved in manual configuration, and most importantly ensure that profibus networks work with many participants of the NETLink® with the correct profibus parameters.

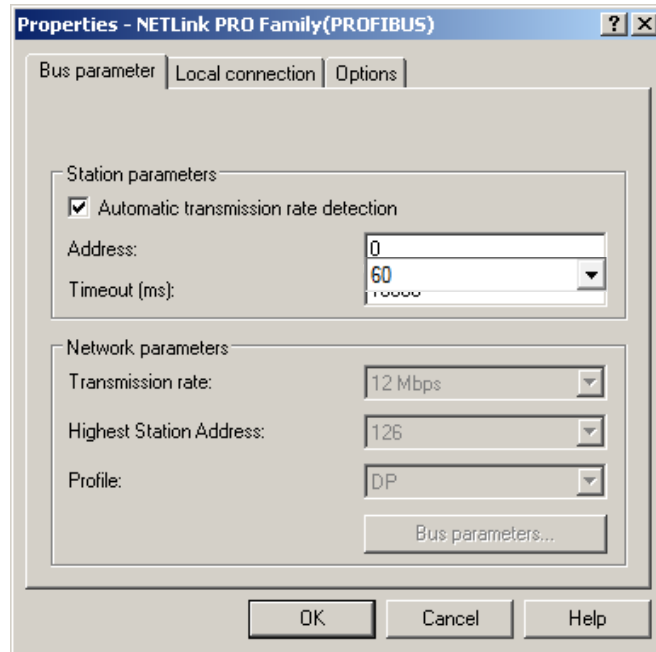

Under PROFIBUS, please note that the auto baud function works best if the ‘Cyclic distribution of the bus parameters’ function is activated in the programmable controller used.



Note regarding the Ttr (Target Token Rotation Time) parameter:

Make sure that the value for the Ttr parameter is not too small. If it is too small, one of the masters on the bus may not get enough time to send data frames. The STEP 7 NetPro module has an option that increases the Ttr time every time a master is added. Siemens provides the following recommended calculation guideline for custom profiles:

Minimum Ttr = 5000 x HSA (highest station address).

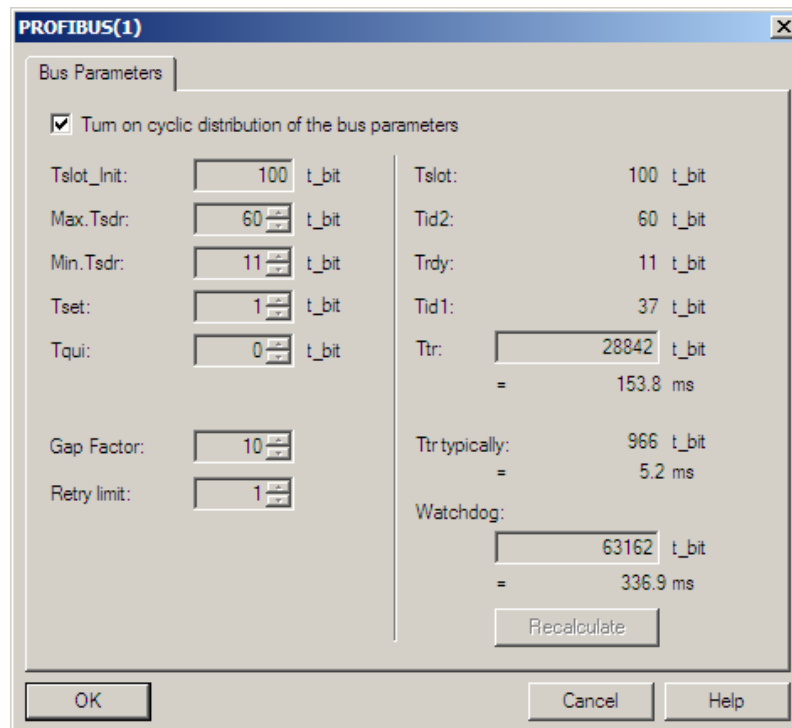

The screenshot above of a hardware configuration of a randomly chosen PROFIBUS CPU shows where to find the switch for cyclic distribution of the bus parameters.

5.1.3 PPI configuration

Generally, the same thing applies under PPI as for the MPI configuration. However, it should be noted that passive participants never transmit the Profibus parameters, and that it is thus not possible to "automatically" determine the bus parameters.



Normally the baud rate cannot be detected automatically at PPI systems.

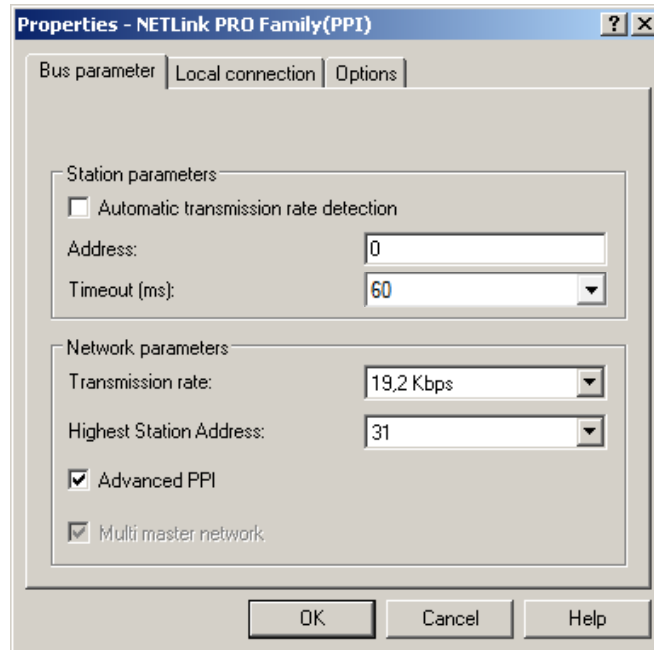

For communications with an EM 277 unit, the "Advanced PPI" option must be enabled.

In addition to the parameter transmission rate already addressed under chapter 5.1.1 and the Highest Station Address, the parameter field for Advanced PPI is also available for selection under PPI:

According to current knowledge, all S7-200 CPUs of the product line 22x should be able to communicate with 'Advanced PPI.' It is recommended to use 'Advanced PPI' if possible.

5.2 Local connection (TCP parameterization)

There are three basic ways of parameterizing NETLink® devices at the TCP end:

- Parameterization via 'Set PG/PC interface'
Existing stations can be reparameterized using the 'Change' button
- Parameterization via the 'NETLink PRO Family configuration' tool (see Section 6).
- Parameterization via the web interface of the NETLink® Gateway (see Section 7.3).

If a NETLink® is configured via the NETLink-S7-NET driver, the following points must be considered:

If the NETLink® is active on the bus when reparameterization is required (e.g. a variable table or block is being viewed), reparameterization is not performed.



The password query must be answered correctly and confirmed with OK.

The ensuing reset would interrupt the NETLink® link

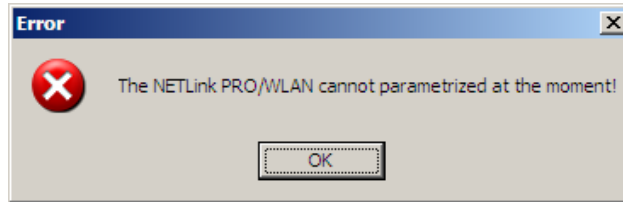

- All NETLink® Gateways be protected against unauthorized reparameterization via a password. If an attempt is made to save a parameter set with an incorrect password, the following messages is displayed:



The default password is 'admin.'

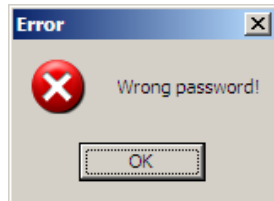

- If the password is correct during parameterization, the new parameter set will be saved and the following message displayed:



Rebooting can take up to 15 seconds.

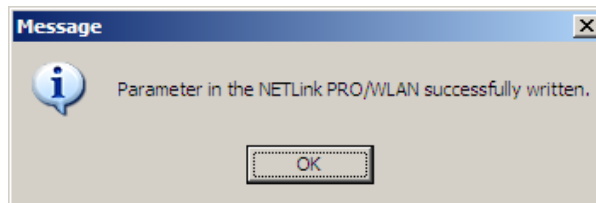

- The NETLink® is now restarted. This can take up to 15 seconds.

5.2.1 Creating a station

The 'New' button takes you to an input dialog box in which you can store the known IP address of an existing NETLink® device and any name for easier assignment.



The NETLink has the IP address 192.168.4.49 on delivery from the factory.

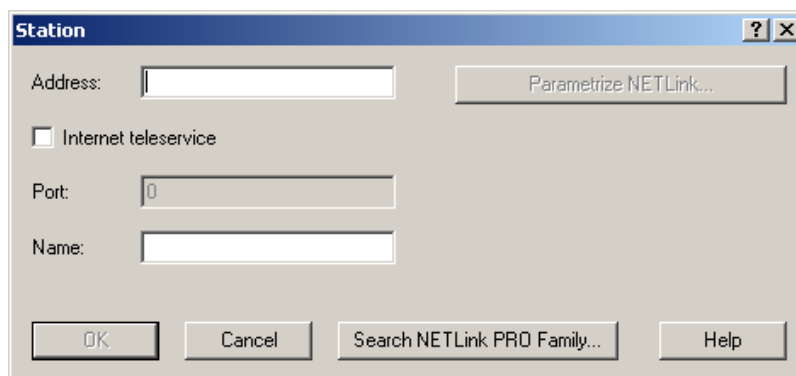

To able to access a NETLink® with the NETLink-S7-NET driver, a station must be set up first. This station is virtually and is not stored in the NETLink® Gateway hardware – it permits easier differentiation if several NETLink® devices from the NETLink® family are used.

Alternative ports can be set with the option "Internet teleservice". If, for example, several NETLink® devices are located in a network



If NAT/PAT is used, a port can be defined if 'Internet teleservice' is selected.

behind a router/switch, these can also be addressed with a port addressing (PAT) adapted here.

The router/switches used must be appropriately configured for this by the responsible network administrator, so that all TCP/IP packages addressed to the router/switch via a pre-defined port are forwarded by this to the NETLink® located behind it.

When the NETLink® is connected in the local network (LAN) or is not located behind a router/switch, the 'Internet teleservice' option must be deactivated.

Internet tele servicing to networks outside of the LAN should always be realized through secured and encoded procedures, such as VPN! To this purpose, the Helmholtz GmbH offers appropriate router hardware.

'OK' stores this station, which can now be used.

It is easier to search for an existing NETLink® device in the local area network. Just click the 'Search NETLink PRO Family...' button.



For the search function of the NETLink® devices, the UDP ports 25342 and 25343 may not be blocked by a firewall.

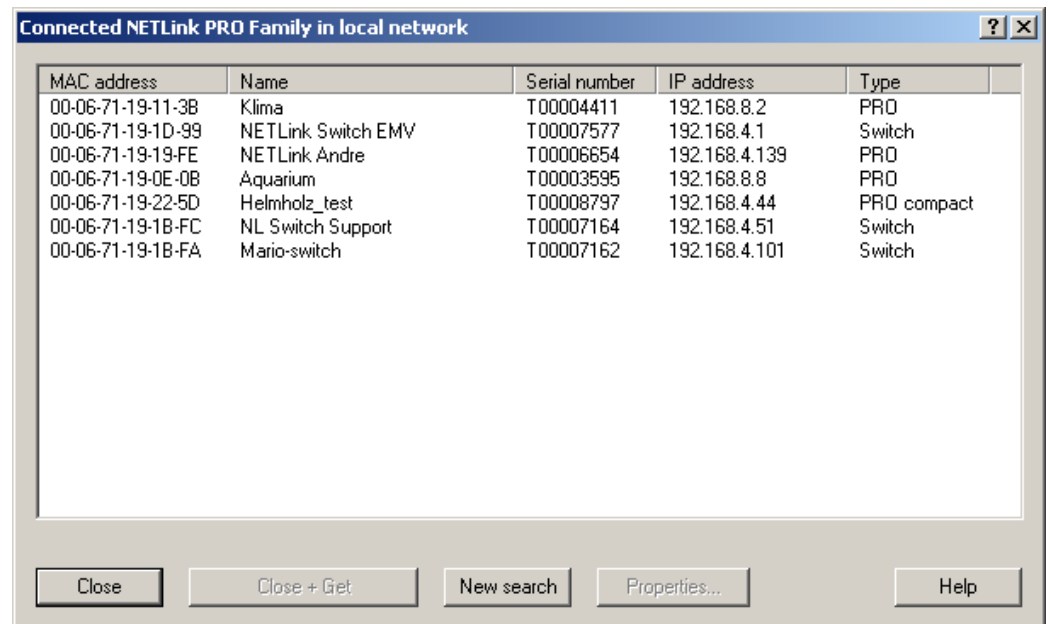

If you now select the required NETLink® Gateway and click the 'Close + Get' button, the following dialog box will appear again:

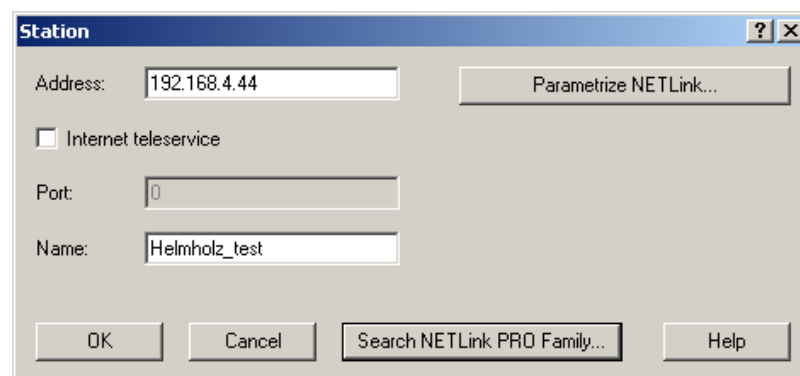

This station can also be saved with 'OK' and is then available.

If you do not want the name that is stored in the NETLink® to be the same as the station name, you can overwrite the station name (e.g. replacing the name 'Helmholz_test' with the name 'Workshop' in the example below).

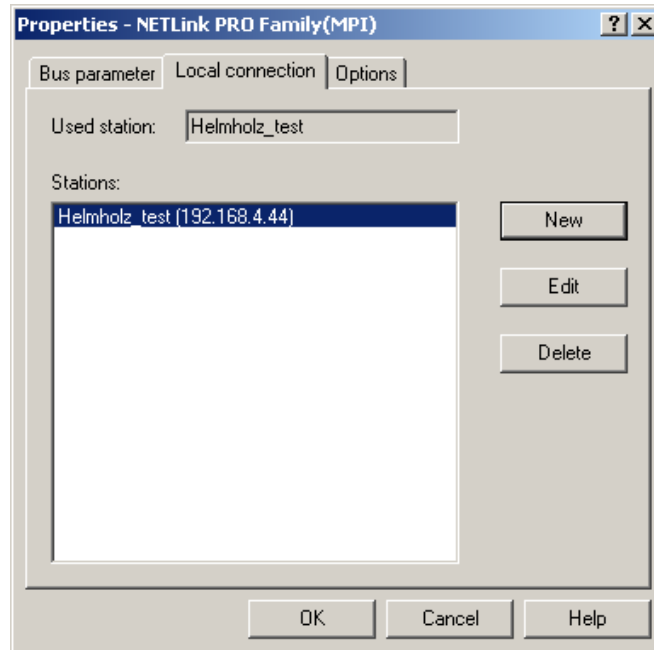

This completes parameterization of the driver.

It may now be necessary to adapt the NETLink® Gateway to the situation in the existing TCP/IP network.

5.2.2 Setting TCP parameters

To change the TCP parameters, select the station in question and open the following dialog box with the 'Edit' button.



As a default, the S7-Net driver attempts to address the NETLINK® via the fixed port 7777

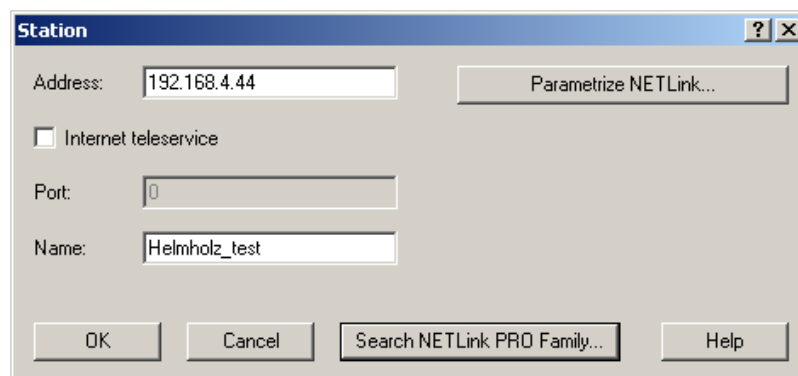

The 'Parameterize NETLink ...' button takes you to a new input form that already contains the current parameters of the NETLink®:

If no NETLink® Gateway can be accessed via the stated IP address, the following message will appear:

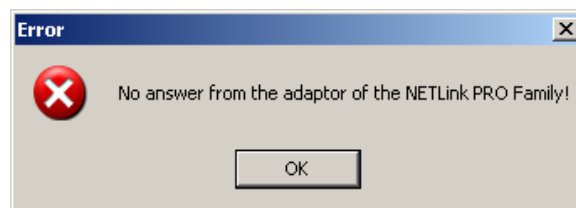

This message can have two causes:

- There is no NETLink® device with the stated IP address (e.g. the device has not yet been switched on or is still starting up).
- The IP configuration of the computer used does not match the IP configuration of the stated NETLink® (e.g. different subnet mask settings).

From the parameterization form shown, it can be seen that not only static IP address allocation but also IP parameter assignment via DHCP is possible.

Both these options are now explained in more detail.

5.2.3 Operation without the DHCP

If a NETLink® is used in a network without a DHCP server (or you want the NETLink® to work with the same IP address on the network despite the presence of a DHCP server) the required IP parameters are stored in the input forms for 'Static parameters.'

In this case, the checkmark is not set in the field 'Get IP address automatically (DHCP).'

Clicking the 'Save in NETLink PRO Family' button saves the parameters in the NETLink® Gateway.

5.2.4 DHCP

To have the NETLink® receive its IP parameters automatically via DHCP, set a checkmark in the field '*Get IP address automatically (DHCP).*'

This then enables the '*DHCP Timeout (s)*' input field. Enter the maximum waiting time here. If the NETLink® Gateway does not receive any parameters from the DHCP server within this time, it will use the stored static parameters to ensure that the device is accessible in the network and can be configured if necessary.

Times shorter than 30 seconds are replaced by the default value (30 seconds) because most DHCP servers require 12 to 20 seconds to assign valid parameter sets.

Clicking the '*Save in NETLink®*' button saves the parameters in the NETLink®.

DHCP has the drawback that a NETLink® Gateway parameterized by this method could theoretically be assigned a different IP address from the DHCP every time it is switched on.

The system administrator responsible for the DHCP server can counter this informing the DHCP server of the MAC address of the NETLink® device. However, this is additional work for the system administrator.

5.2.5 Additional features

The '*NETLink PRO Family properties*' input form contains a '*NETLink PRO Family properties*' group box with further options that are explained here:

- **Name:**
Here a name can be given to the NETLink® Gateway that identifies it better when it is shown in the search window. The name is stored in the device.
The name may designate the location (e.g. conveyor HG1), the user (e.g. Mr. Example), or anything else.
- **Web interface active:**
If there is a checkmark in this checkbox, the parameterization of the NETLink® can be viewed and changed, if necessary, in any standard Browser (tested with Firefox and Chrome) as long as the password (if one has been set) is known.
Section 7 provides more detailed information about what you can do with the web interface.
- **Changing the password:**
A password must first be defined during the initial start-up. Please note the instructions in Chapter 7.2!

A password that you have already set can be changed here. The configuration of the NETLink® can only be changed with the help of the password. This applies to parameterization both via the driver and via the web interface.

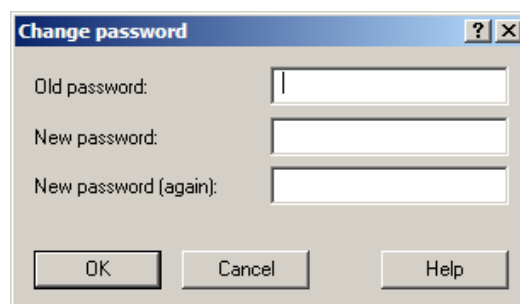

Clicking the 'Save in NETLink®' button saves the parameters in the NETLink® device in this case, too.

5.3 Options of the driver

Under the options of the NETLink-S7-NET driver, it is possible to set the language of the output and help texts of the driver.

It is also possible to read out the version numbers of the driver files used.

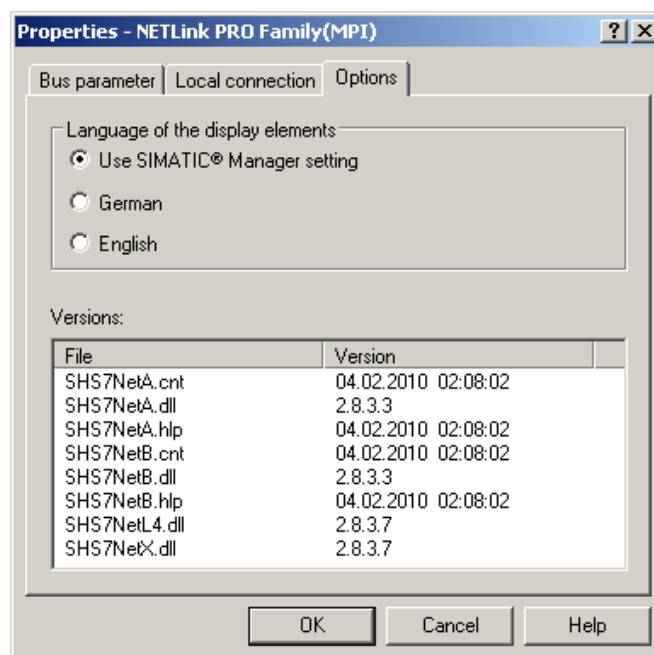

5.3.1 Language setting of the display elements

The languages German and English are currently available.

After switching over the language, the setting window must be opened again to apply the changes.

5.3.2 Version information

The names and version number of all driver files are listed here.

If support is needed, this data is used to obtain information about the components used quickly and effectively.

5.4 Diagnostics

For rudimentary diagnostics of the connected bus two sub functions are available:

- Display bus nodes
- Display bus parameters

Before the diagnostics functionality is used, a valid station must be created and a plausible bus configuration set.

5.4.1 Bus members

A list of all available nodes at the bus will be generated by clicking the button 'Read.'

With activating the option 'Read MLFB number' the order numbers of all devices supporting this function will be displayed too.

The possibility to detect all connected nodes depends on the parameterization of the PG/PC Interface. It is recommended to enable auto baud functionality at MPI and PROFIBUS.



The "Station type" column lists both active (master) and passive (slave) stations.

The NETLink unit being used will be shown as a Station address.

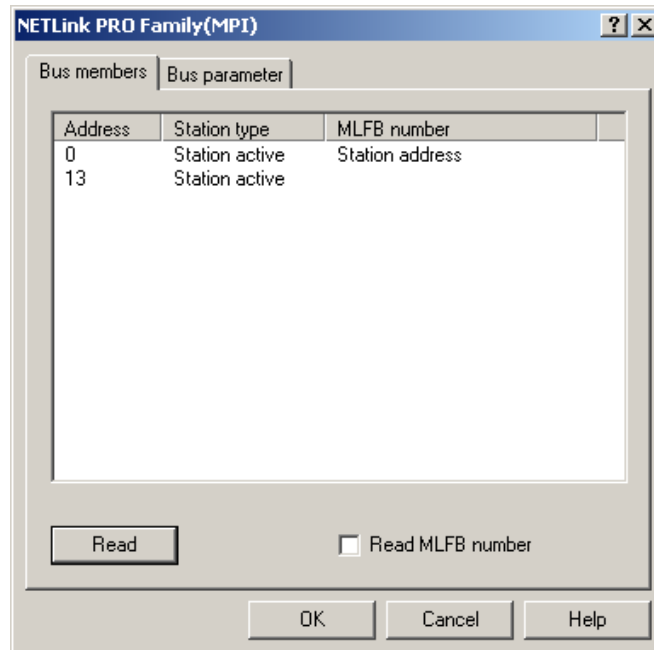

5.4.2 Bus parameters

If it is possible a list of all bus parameters will be displayed by clicking the button 'Read.'

The possibility to detect the bus parameters depends on the parameterization of the PG/PC Interface.

It is recommended to enable auto baud functionality at MPI and PROFIBUS.

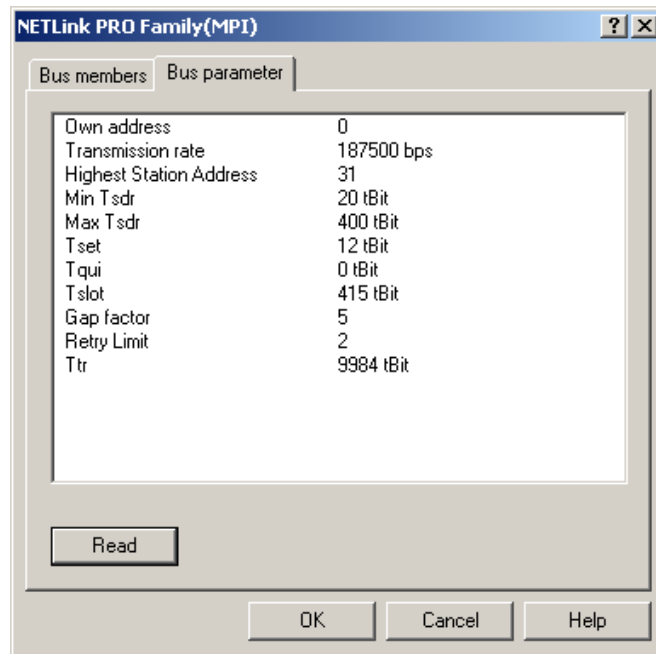

6 The Tool: 'NETLink® PRO Family Configuration'

If a Simatic Engineering Tool is present on the configuration computer that installed the PG/PC interface, it is possible to configure a NETLink® both via the integrated web interface (see chapter 7.3) and with the configuration tool.

The tool is accessible under 'Start/Programs/Helmholz/NETLink-S7-NET/NETLink PRO Family Configuration' after the NETLink-S7-NET driver has been installed.

After this program has been called, the network will be searched for connected NETLink® MAC addresses:



The set IP address of the connected NETLink® devices is not relevant for search function. The search function uses the device-specific MAC addresses. All other data in the list is for information only.

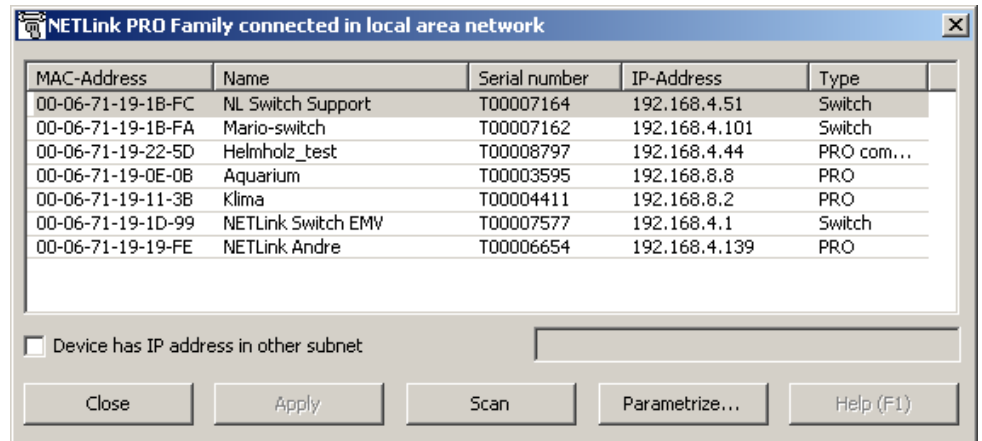

The scan can be repeated at any time by pressing the "Scan" button again. Having chosen any NETLink® adapter out of the provided list, it is possible to configure the device after clicking 'Parameterize...' as described in Section 5.



In order to be able to use the scan function to find NETLink® devices, make sure that UDP ports 25342 and 25343 are not being blocked by a firewall.

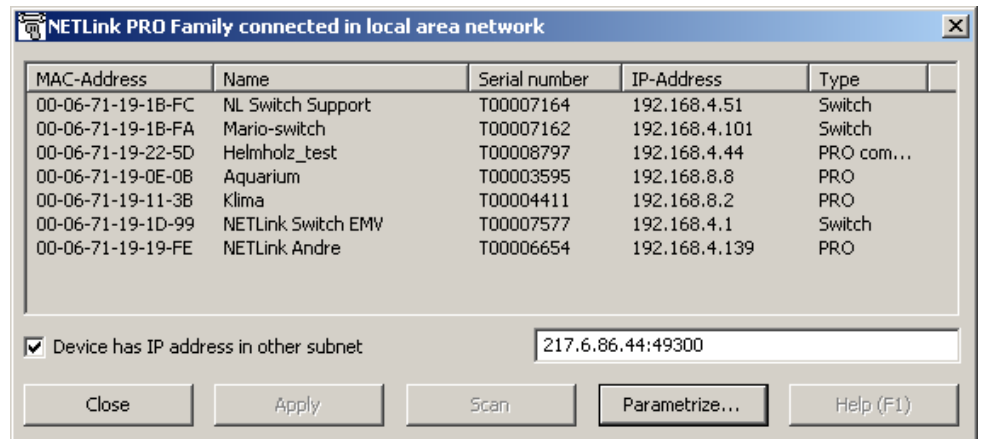

An extended function enables direct parameterization across network boundaries. To do this, activate the radio button and enter the known IP address of the NETLink® (the example includes the optional address of the port – separated by a colon) in the empty field. The corresponding configuration menu then opens when "Parameterize..." is clicked.



All NETLink® devices has the IP address 192.168.4.49 on delivery from the factory.

7 Possibilities of the Web Interface

If it has not been deactivated by the user, the web interface of all NETLink® Gateways can be opened with any standard browser (tested with Firefox and Chrome).

The web interface is intended to support the user intuitively with information and configuration tasks.

7.1 Home Page

The home page, which is located at `'http://<ip-address>'`, is a basic address and navigation starting point for the user.

One can go to the status page from this page without logging in. All other menus are only accessible following prior identification with user name and password.

7.2 Setting up access

As of firmware version 2.58, the user must define an individual password when calling up the website for the first time. This must then be saved in NETLink. The following view appears when an individual password hasn't been saved in the NETLink:



The standard password "admin" from older device versions may no longer be used. The new password to be set by you must not be longer than 8 characters, spaces are not permitted. The characters after the 8th character are cut off!

In the delivery state, the default password consists of the last 8 Hex characters of the device MAC address. This information is printed on the housing and upper and lower case is ignored. Also note the following syntax: Example of MAC address: 00:06:71:19:1B:FC -> resulting password: 71191BFC

The new password to be set by you may not exceed 8 characters and spaces are not permitted. The characters after the 8th character are cut off!

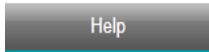
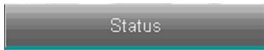

Every submenu features a Help button that can be used to access descriptions of relevant details and functions.



The values shown on this page are all volatile!

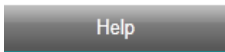

Every submenu features a Help button that can be used to access descriptions of relevant details and functions.



The default username is the full NETLink product name.

For more information, please refer to the corresponding Quick Start Guide.

Please note that both the username and password are case-sensitive!

In the delivery state from FW 2.58, the default password consists of the



Rebooting can take up to 15 seconds.

7.3 Status Page

The status page, accessible via a link on the home page, provides the user with information without allowing unauthorized reconfiguration of a NETLink®.

The page provides general information:

- firmware version, number of possible connections, etc.), and specific information (baud rate, active stations, DHCP status, etc.)

A “Diagnostic Page” is also implemented, which can be useful for troubleshooting, for example. To make use of this function, “Go Online” must be activated for the NETLink® adapter on the bus system. This can be done with an engineering tool such as STEP7 or by using the “Go Online” button on the status page. This function can also be switched on permanently on the “Basic Configuration” page.

Because all NETLink® Gateways are also active as a single master, it is also possible to search for passive stations only. The search is started by clicking “Search Passive Stations.” The updated status of verified stations is then displayed.

7.4 Configuration page

The configuration page, accessible via a link on the home page, is a configuration interface for the user.

- It can be used to modify device-specific parameters, TCP parameters, and bus-specific parameters, as well as to change the unit’s default username and password.

Before this page is opened, the user name and the password must be entered.

Please remember that the user names/passwords that you have defined for this configuration interface cannot be reset by any “master reset”. Please contact our technical support if you are no longer able to access the safety-relevant pages of the Web interface with the access data known to you.

The bus parameters can also be adapted to the single master functionalities. For further details on the RFC1006 function see section 8.

With the ‘Submit’ button, the inputs are checked for plausibility. You may then be shown which inputs are incorrect and what correct input would look like at this point.

Before the parameters are actually saved, you will be shown all the changes you made the way they will be stored in the NETLink® unit’s non-volatile memory (after you click on the “Store” button). After clicking on the “Store” button, the NETLink® unit will be automatically restarted so that the configuration you set up can take effect.

With the Web interface, a NETLink® could be started both locally and remotely. This is done by clicking the ‘Device Reboot’ button.

Security

Help

Every submenu features a Help button that can be used to access descriptions of relevant details and functions.

!
If you forget the IP addresses on the whitelist, you will no longer be able to reconfigure the NETLink® device from an external PG/PC.

!
Notice deviation by usage of proxy servers.

⏏
Rebooting can take up to 15 seconds.

7.5 Security page

The security page serves as a configuration interface that allows users to set up access restrictions.

After the security query (see 7.4) has been correctly answered, the user has write-access to all parameters that are implemented for TCP security etc.

Up to 12 IP addresses can be added to the device's whitelist. In order to use the TCP access list, the corresponding "ON" option must be enabled (individual list entries are disabled by default). Whitelisted IP addresses must be entered using the four-octet format (e.g.: 192.168.4.59). If you want to delete a whitelisted address or undo its addition to the whitelist, simply select "OFF" in the corresponding row.

Once the configuration is saved, only stations that are whitelisted in this table will be able to establish TCP connections to the NETLink® unit.

TCP/IP addresses that are not in the white list have read-only access to the web interface. MPI, PPI, or PROFIBUS functionalities cannot be used. The configuration of the NETLink® is also prevented.

It is also possible to activate additional write protection (primarily for CPUs) for any bus nodes connected to the NETLink®. If the NETLink® is used, for example, as a communications adapter for representing visualization values, only data from the connected controllers can be read out if write protection is active. In this way, manipulation of the CPU sequential program is ruled out.

This assumes, of course, that the access data for the NETLink® web interface are secure.

Attention: To prevent their use by unauthorized persons, any proxy servers that exist in company networks may not be entered in the white list. If so, safe use of a NETLink® Gateway is not guaranteed.

With the button 'Factory defaults' it is possible to restore all parameters to the as-delivered state of the NETLink® device. All user-defined configurations will be deleted by this function.

By clicking the 'Submit' button, the inputs are checked for plausibility. You may then be shown which inputs are incorrect and what correct input would look like at this point.

If all your settings are consistent, you will be shown the changes you made the way they will be stored in the NETLink® unit's non-volatile memory after you click on the "Store" button.

After the new parameterization data have been stored, the NETLink® is restarted to activate the new configuration.

A NETLink® can be started both locally and remotely via the security interface. This can be done by clicking the 'Device Reboot' button.

Observe Variables

Help

Every submenu features a Help button that can be used to access descriptions of relevant details and functions.

7.6 Observing variables

In addition to the “*Observing Variables*” function in the Simatic engineering tools, all NETLink® Gateways also provides this function via the web interface. The operating menu can be accessed via the ‘*Observe Variables*’ link. A RFC 1006 communication channel is assigned for these functions.

You can use the drop-down menu to select an active MPI/PB address, while the number of variables you want to monitor can be set within a range of 1 to 10 according to your own preferences. The page only supports decimal, hexadecimal, and binary display formats, making the output values easy to read and use for diagnostic purposes. The page supports monitoring for the following units (for the address range):

AB, AW, AD, EB, EW, ED, MB, MW, MD, DBB, DBW, DBD, counter, and timer.

To display the desired values, you use the ‘*1x fetch*’ button for a single value update or ‘*cyclic fetch*’ for a permanent online query.

The value update is currently permanently set to 0.5 seconds. Even if multiple stations access this function from the TCP/IP end, only one connection resource is ever assigned in a NETLink®. Moreover, data exchange via MPI/PB and/or RFC 1006, the ‘*Observe Variables*’ action has the lowest priority. The update time in the Web interface therefore depends on the concurrent bus load.

Once you have configured all the settings you want on the page, click on the “*Save Configuration*” button (with all the variables and free-text descriptions—consisting of a maximum of 32 characters—you created) to save them on the NETLink® unit.

7.7 NETLink® WLAN configuration

This section provides only the functions of a NETLink® WLAN adapter. The commissioning of the available wireless modes is described step by step.

WLAN Configuration

Help

Every submenu features a Help button that can be used to access descriptions of relevant details and functions.

7.7.1 NETLink® WLAN in the infrastructure mode (AP)

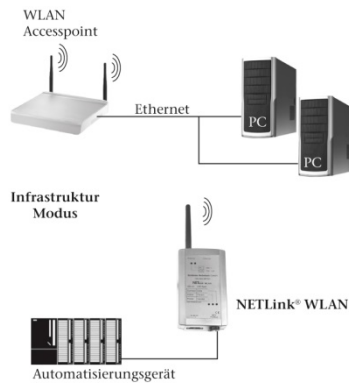

When using the infrastructure mode the communication of two WLAN components is handled by a mediation unit, an access point (AP). The AP functions as central coordination point of the

communication. The infrastructure mode that has to consist of at least one WLAN end device and an AP is also called BSS.

Comparable to a mobile network the AP establishes a radio cell that is spatially restricted. WLAN end devices such as NETLink® need to log on to this radio cell and authenticate to it. The authentication does only occur if the access data to the radio cell is stored in NETLink® WLAN.

In order to log on NETLink® WLAN to an infrastructure net the following aspects have to be regarded:

- The WLAN function needs to be activated in NETLink® WLAN
- The infrastructure mode needs to be selected in NETLink® WLAN
- The SSID of the access point needs to be stored in NETLink® WLAN
- The encoding settings of NETLink® WLAN need to correspond with those of the access point

7.7.2 NETLink® WLAN in the ad hoc mode

The ad hoc mode describes an operating mode in which the WLAN components communicate with each other directly. Therefore, no central coordination point (access point) is involved in the communication. The data transfer is realized directly by and between the WLAN components. That is why this operating mode is also called “peer to peer mode”.

In order to connect NETLink® WLAN directly with a PG/PC the following aspects have to be regarded:

- The WLAN function needs to be activated in NETLink® WLAN
- The ad hoc mode needs to be selected in NETLink® WLAN
- NETLink® WLAN needs to be defined with a station name
- The channel on which NETLink® WLAN is supposed to send needs to be selected
- The desired encoding settings need to be made (in the ad hoc mode you can only use the relatively insecure WEP encoding standard)
- The party that starts the communication has to be able to understand one of the WLAN standards 802.11b or 802.11g furthermore the NETLink® WLAN has to have a fixed IP address, since the adapter does not serve as a DHCP Server.

*A hot spot must be set up under Windows 10! Further information can be found at:
www.support.microsoft.com*

7.7.3 Connection establishment PC to NETLink® WLAN in the unencrypted ad hoc mode

At this time it is assumed that NETLink® WLAN already disposes of a station name, that it is reachable via WLAN in the ad hoc mode and that the WLAN connection is configurable via the Windows WLAN assistant.

1. Step: The WLAN adapter has recognized the wireless networks in operating distance.



2. Step: This screen appears when you open the 'Wireless Networks' manager by clicking the WLAN symbol.

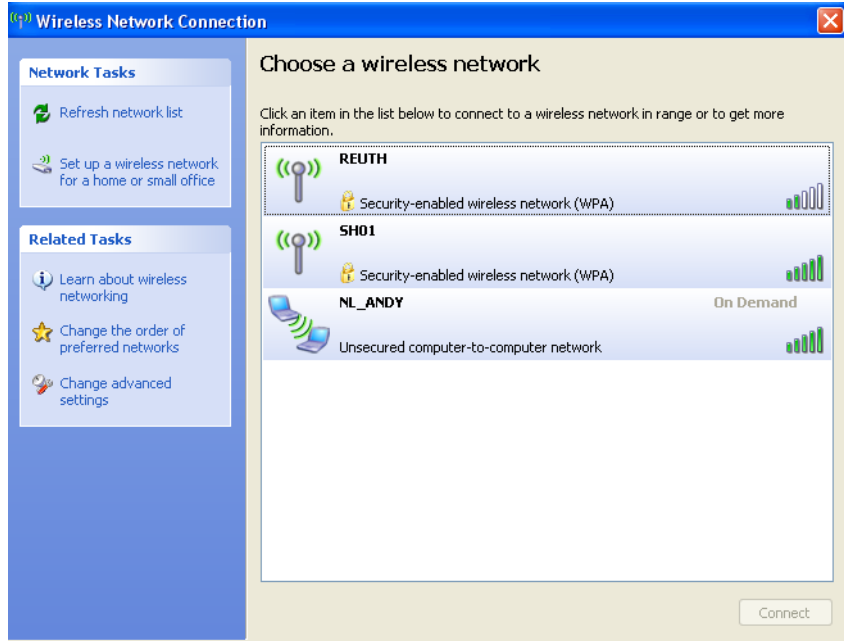

3. Step: Now select the NETLink® WLAN, here 'NL Andy', that you wish to connect to.

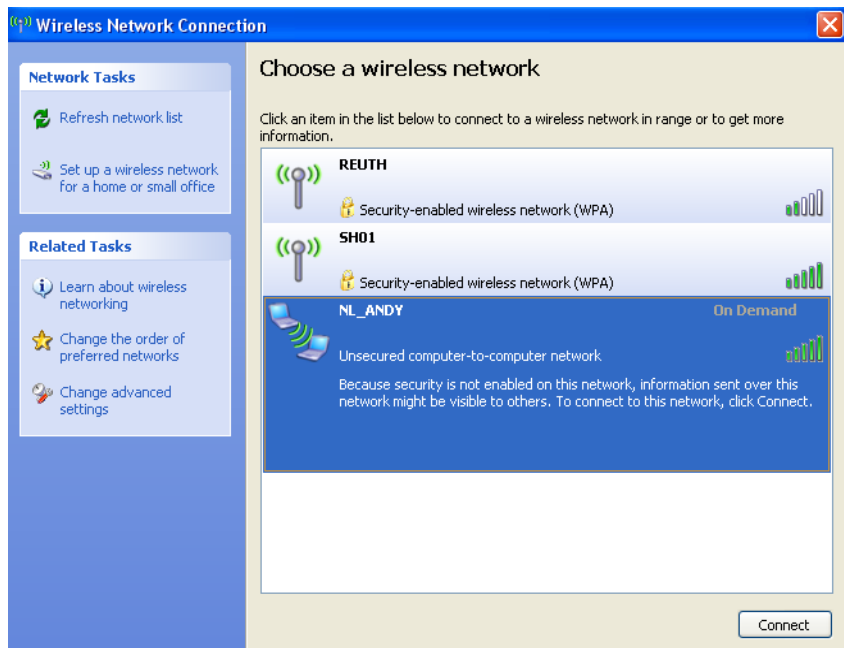

4. Step: In order to establish the connection it is necessary to click the 'Connect' and the 'Connect anyway' buttons.

The 'Connect anyway' button will only appear if no encoding is set in NETLink® WLAN.

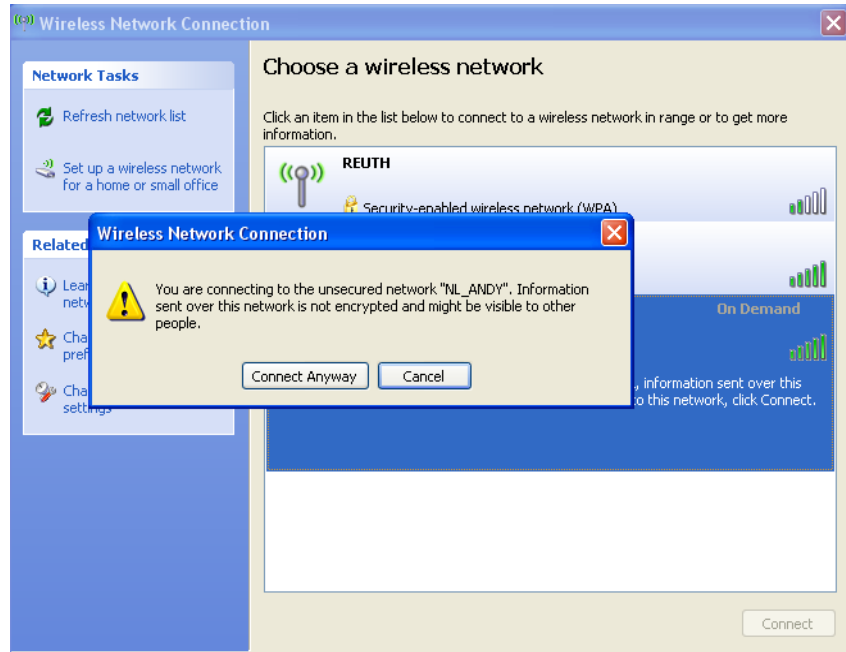

5. Step: The connection to NETLink® WLAN is now successfully established, and it can be implemented e.g. via the PG/PC interface parameterization.

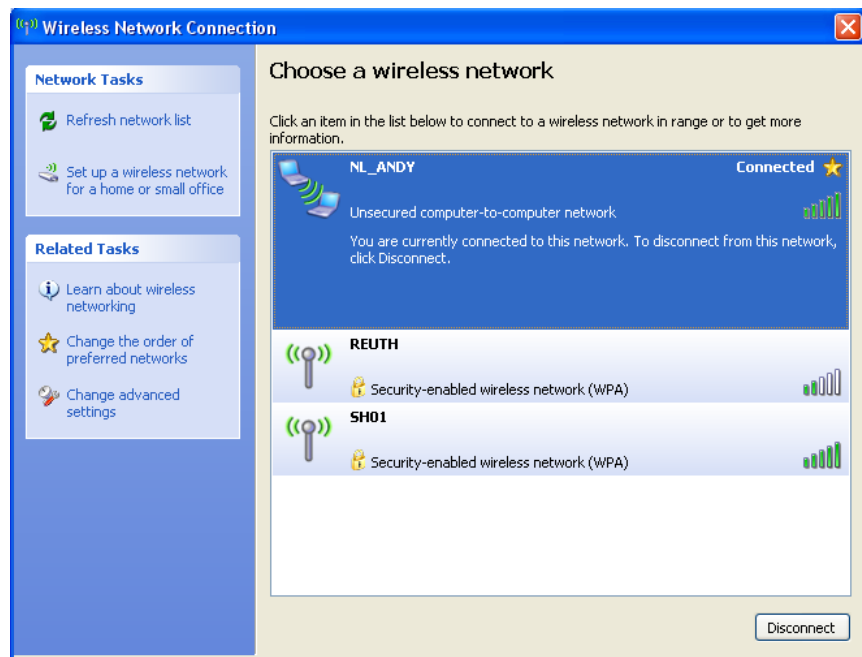

7.7.4 Connection establishment PC to NETLink® WLAN in the encoded ad hoc mode

1. Step: The WLAN adapter has recognized the wireless networks in operating distance.

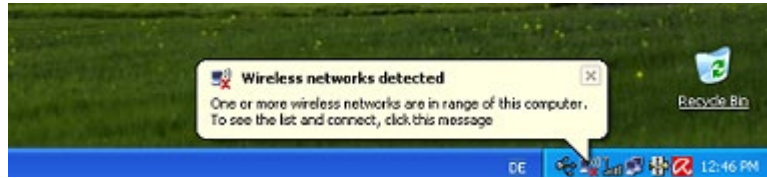

2. Step: This screen appears when you open the 'Wireless Networks' manager by clicking the WLAN symbol.

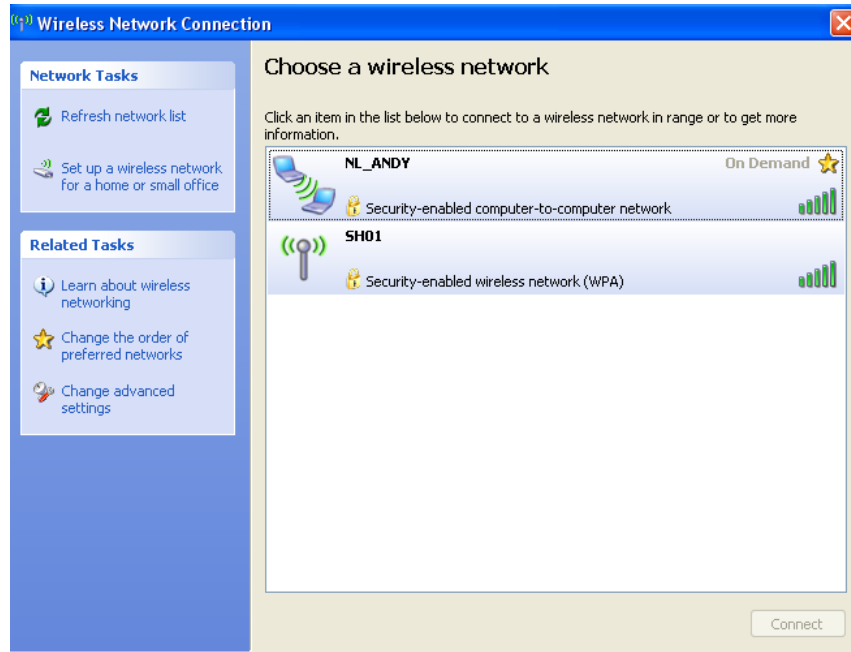

At this time it is assumed that NETLink® WLAN is configured similar to the configuration shown on the following screen and that it is accessible via WLAN.

NETLink WLAN Configuration

Wireless Network Configuration

WLAN: ON OFF

Network Type: Infrastructure Ad Hoc

Channel:

Network Name (SSID):

Station Name (SSID):

Adhoc Scan Network:

Network Security

Security:

Authentication:

Encryption:

Key Type: Passphrase Hex

Key:

Char Count: Show Key:

Keep in mind to enter 26 characters in the box for the encoding key when using WEP 128 bit. The characters are only displayed if you tick the check box 'Show key'. Otherwise the 'Key' is hidden.

Furthermore the WLAN connection in this example has to be configurable via the Windows WLAN assistant or via another producer.

- 3. Step: Now select the NETLink® WLAN, here 'NL Andy', that you wish to connect to and click the 'Connect' button.

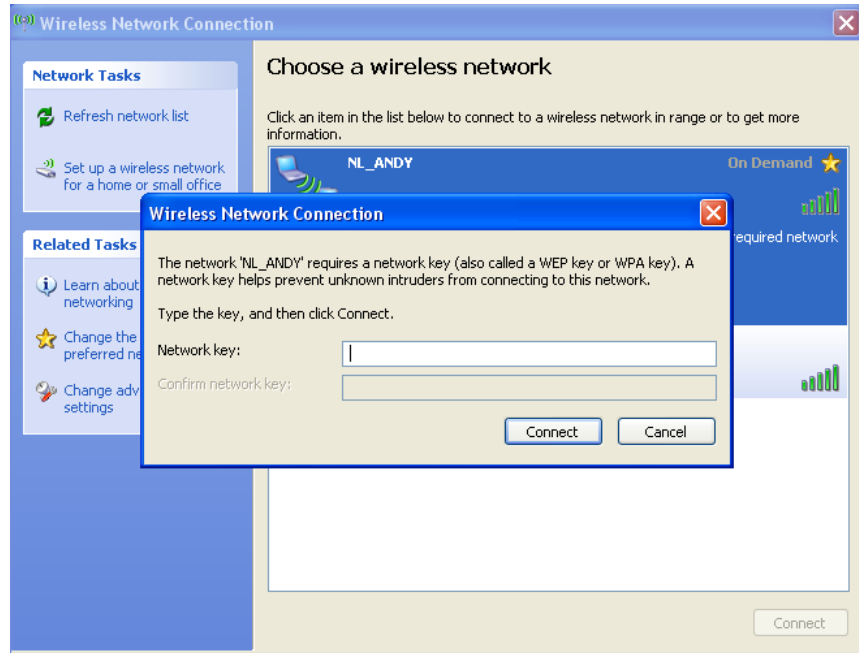

- 4. Step: Now enter the valid key for the respective NETLink® WLAN and confirm by clicking the 'Connect' button. Windows does not display the key, either, but keeps the characters hidden.

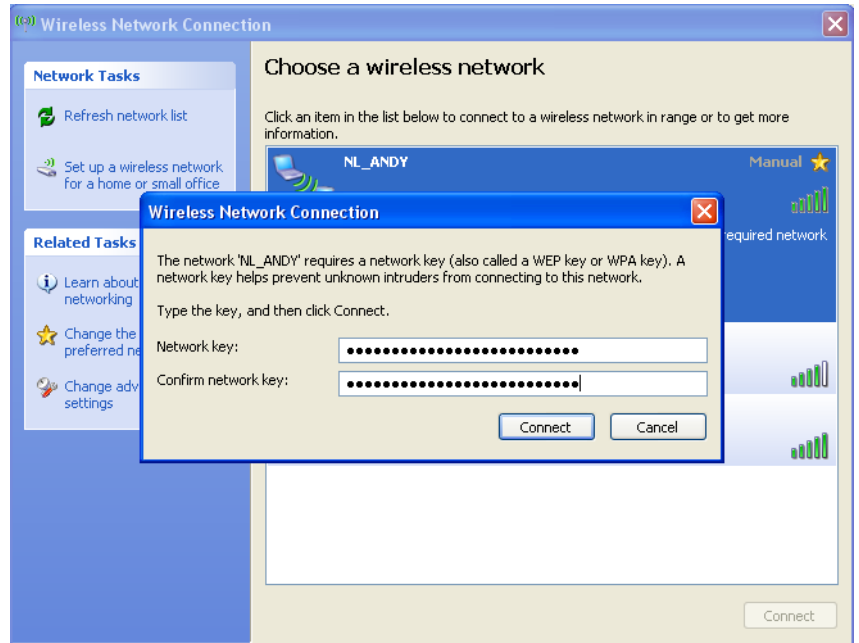

- 5. Step: The manager now indicates to obtain a network address. That is not entirely correct, since NETLink® WLAN cannot allocate IP addresses (see section 10.2). Therefore, the wireless network connection needs to be given a fixed IP beforehand.

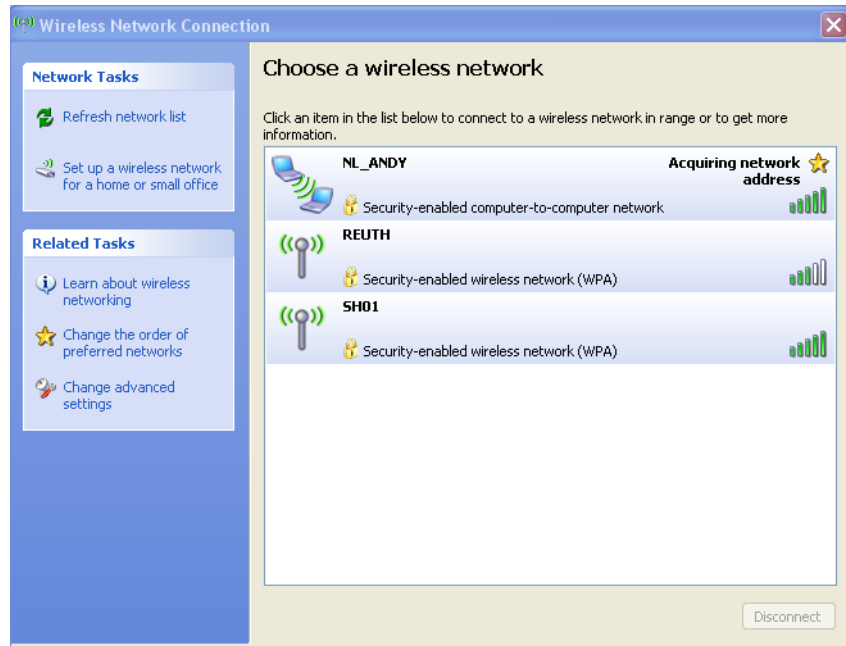

6. Step: Afterwards the following screen is shown. The connection is now properly established, and NETLink® WLAN can now be used e.g. as programming adapter.



If a wrong key is entered the PC will establish a connection anyway. However, NETLink® WLAN can not be used via this connection.

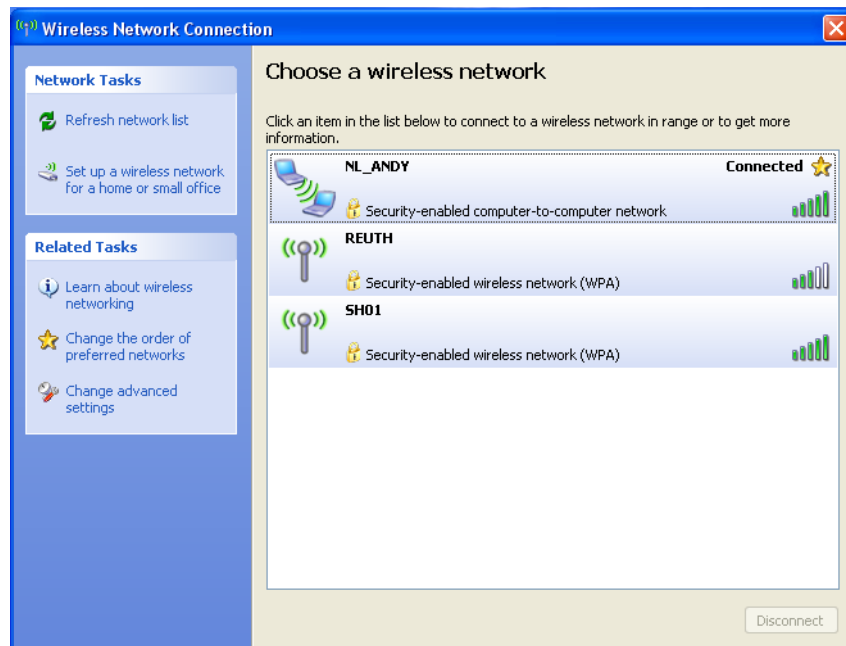

8 RFC1006-Function (S7-TCP/IP)

As an additional option, the NETLink® Gateway can implement the RFC1006 protocol (also known as S7-TCP/IP or as ISO on top of TCP). RFC mode is always active and does not have to be specifically enabled. A NETLink® Gateway automatically goes “online” as soon as it detects an RFC frame.

Because many visualization system manufacturers have implemented this protocol to implement connections with CPs from Siemens (e.g. CP343 or CP443), a NETLink® with RFC1006 is an alternative to communication with these visualization systems.

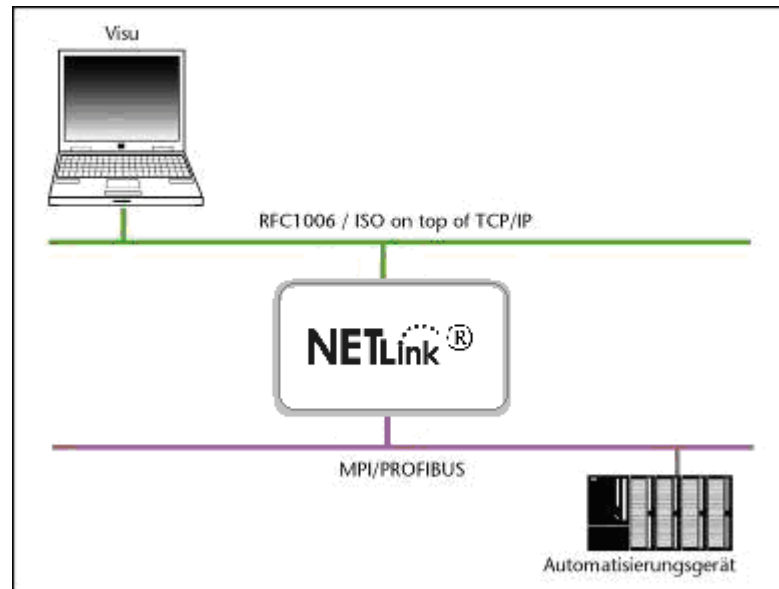

!

Please also observe the application-specific instructions in Troubleshooting and the additional documentation on the subject of SCADA, HMI, and OPC (example applications – for more information see 11.3 ff)..

The RFC1006 functionality of the NETLink® Gateway is also supported by S7-200 systems.

The following software packages with RFC1006 support have so far been tested in conjunction with the NETLink® products:

- WinCC V6.0/V7.0 (Siemens AG)
- WinCC flexible 2005/2007/2008 (Siemens AG)
- ZenOn V6.2 (COPA-DATA)
- PROCON-Win V3.2 (GTI Control)
- S7-OPC Server, V3.1 and higher (Helmholz GmbH)
- AGLink V4.0 (DELTALOGIC Automatisierungstechnik GmbH)
- INAT-OPC-Server (INAT GmbH)
- WinCE 5.0 Terminal TP21AS (Sütron Electronic GmbH)
- KEPserverEx V4.0 (KEPware Inc.)
- InTouch V9.5 (Wonderware GmbH)

8.1 CPU Addressing with Rack/Slot and TSAP

These RFC 1006 functions can be used to access specific modules on an automation system. For this to be possible, direct commu-

nications are only allowed with a single preconfigured station. This station will then forward all data packets that are not meant for it to the desired rack/slot and relay the corresponding answer back to the NETLink® unit.

To use this feature, you will have to enter the rack and slot numbers for the target address into the relevant RFC 1006 driver on the SCADA/HMI application you are using.

For example, if you wanted to communicate with target address 2, you would enter the following on *Visu 1*: Rack 0, Slot 2.

If, on the other hand, you wanted *Visu 2* to communicate with target address 49, you would enter the following on *Visu 2*:
Rack 1, Slot 17.

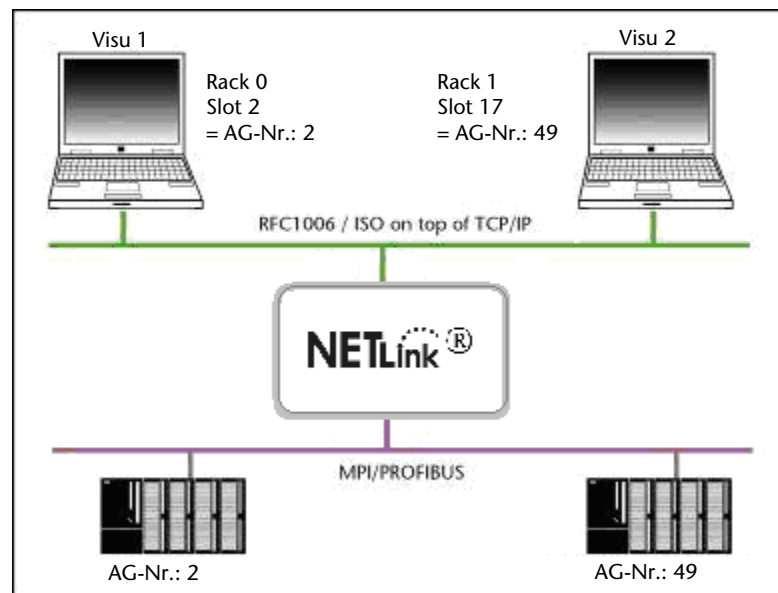

Section 11.3.3 includes a table that shows addresses converted into rack and slot values.

There are many parameter configuration tools that do not have fields with the names “Rack” and “Slot.” Instead, these tools usually have an input field called “Remote TSAP” that is two bytes long and needs a hex format value. This field, of which only the lower byte is important for our purposes, is configured as shown in the following examples:

If you wanted to communicate with target address 2, you would enter the following: Remote TSAP 0202_{hex}.

If, on the other hand, you wanted to communicate with target address 49, you would enter the following: Remote TSAP 0231_{hex}.

Section 11.3.3 includes a table that shows addresses converted into remote TSAP values.

If you want to do the calculation yourself, you can use the following simple formula: $Rack * 32 + Slot = Address$.

For more information, please refer to Section 10 (Troubleshooting).

Helmholz GmbH has additional documents with example applications for SCADA, HMI, and OPC available (see Section 11.3ff).

9 Bus Parameters in Single Master Operation

If the NETLink[®] Gateway is connected to a bus system on which no other master is active, the NETLink[®] generates the token itself. This feature can be enabled on the web interface under “Basic Configuration.” In most cases, it will also be necessary to configure the corresponding bus parameters accordingly.

The “NETLink Bus Address” field must be used to assign the NETLink[®] device its own station address, i.e., the station address that it will use to communicate on the bus (the address is set to 0 by default).

The value for this address may be anywhere in the range 0 through 126. It is a precondition for this that the selected address is not larger than the HAS (highest station address) and is not already being used for another device on the bus.

9.1 Storing specified bus parameters

For bus profiles MPI and PPI, no other adaptations besides the baud rate are usually necessary. However, the DP setting must be configured carefully.

When parameterizing, please note that all parameters for PROFIBUS are interdependent. That is, if a parameter, e.g. the baud rate, is changed, all the other parameters usually also change.

For MPI, on the other hand, all parameters besides the baud rate are fixed. That is, if an MPI connection of increased from, say, from 187.5 Kbps to 12000 Kbps, all other parameters can/must remain unchanged.

The following parameters must be taken into account:

- Baud rate: The required baud rate is entered in Kbps. For example ‘187.5’ or ‘12000’.
The possible values are:
9.6; 19.2; 45.45; 93.75; 187.5; 500;
1500; 3000; 6000, and 12,000.
- HSA The highest station address is entered here. For MPI generally ‘31’ and for PROFIBUS ‘126.’ However, any values can be used that are not equal to the default values.
- TSlot_Init This value is always ‘415’ for MPI – whatever the baud rate. For PROFIBUS the appropriate value should be read from the PROFIBUS project.
- Ttr This value is always ‘9984’ for MPI – whatever the baud rate. For PROFIBUS the appropriate value should be read from the PROFIBUS project.

- Max. Tsdr This value is always '400' for MPI – whatever the baud rate. For PROFIBUS the appropriate value should be read from the PROFIBUS project.
- Min. Tsdr This value is always '20' for MPI – whatever the baud rate. For PROFIBUS the appropriate value should be read from the PROFIBUS project.
- Tset This value is always '12' for MPI – whatever the baud rate. For PROFIBUS the appropriate value should be read from the PROFIBUS project.
- Tqui This value is always '0' for MPI – whatever the baud rate. For PROFIBUS the appropriate value should be read from the PROFIBUS project.
- Gap This value is always '5' for MPI – whatever the baud rate. For PROFIBUS the appropriate value should be read from the PROFIBUS project.
- Retry This value is always '2' for MPI – whatever the baud rate. For PROFIBUS the appropriate value should be read from the PROFIBUS project.



Incorrect bus parameters can interfere with the bus considerably!

Please note that under unfavorable circumstances an incorrectly parameterized NETLink® Gateway can interfere with the bus to the extent that regular bus operation is no longer possible.

9.2 Addressing with Routing over RFC

Since the RFC 1006 protocol normally cannot be used to transmit PLC routing information (MPI<->PROFIBUS) in a “connect request” frame, it was necessary to implement various addressing methods in order to make the device compatible with all possible communication setups. The parameters that are required for this purpose can all be configured on the web interface used to manage NETLink® products.



The required paths within the automation system are defined and managed by the CPU => Routing.

These addressing methods are “RFC Multicomputing with TSAP” (see Section 9.2.1) and “RFC Routing via CPs with TSAP” (see Section 9.2.2).

These two addressing methods, which cannot be used together, make it possible to use most communication setups that can also be used with NETLink-S7-NET drivers.

9.2.1 RFC Multicomputing with TSAP

This function makes it possible to communicate with more than one CPU on a rack (\Rightarrow multicomputing) in S7-400 systems without any need for the additional CPUs to be connected to the same PROFIBUS cable.

For this to be possible, direct communications take place with only one single configured station (CPU address 49 in this example). This station then forwards data packets to the desired rack/slot.

If you use this mode, the following settings must be configured on the web interface configuration page:

- “RFC Multi Computing with TSAP” must be enabled (ON)
- “RFC Routing over CP with TSAP” must be disabled (OFF)
- Enter the address for the communication station that will be communicating with the multicomputing system as the “Bus address”

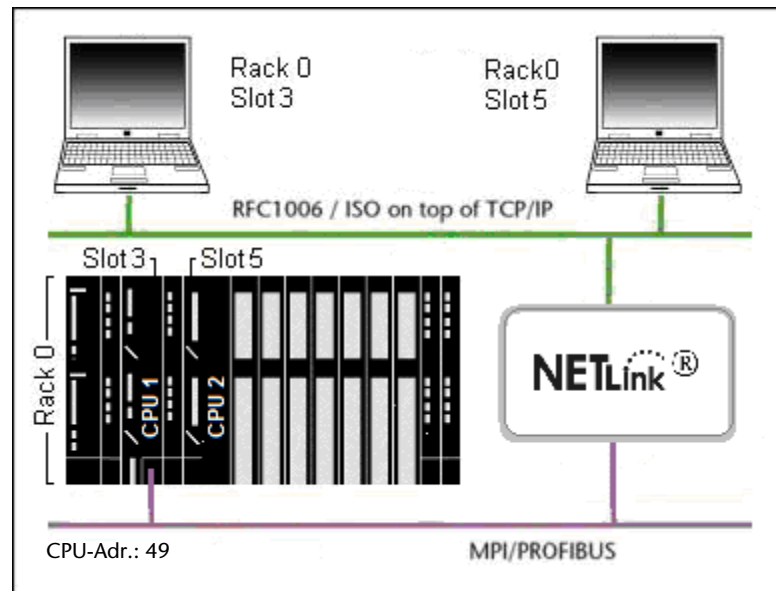

The rack/slot address for the station that will be used to communicate on the rack must be configured in the communication software (in the above example: R/S = 0/3 for CPU 1 and R/S = 0/5 for CPU 2)

9.2.2 RFC Routing over CP with TSAP

This configuration makes it possible to use computer applications to address multiple CPs connected to the same bus by using the CPs' PROFIBUS addresses. The applications will “route” the frame to the connected CPUs based on the configured rack/slot setup.

For this to be possible, direct communications only take place with one single configured station (CP address). This station then forwards data packets to the desired rack/slot.

If you use this mode, the following settings must be configured on the web interface configuration page:

- "RFC Multi Computing with TSAP" must be disabled (OFF)
- "RFC Routing over CP with TSAP" must be enabled (ON)
- The numeric values for the rack/slot combination being used must be entered into the "Rack" and "Slot" fields

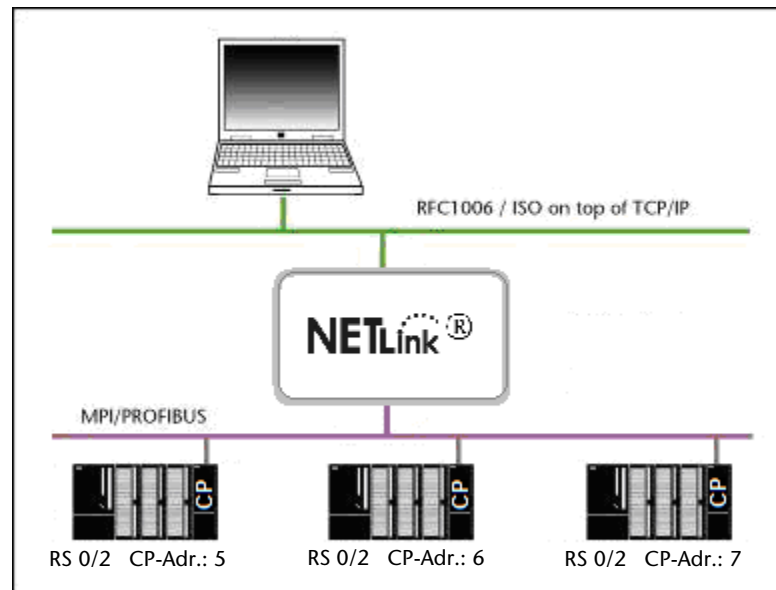

If the CP modules are not sending the required bus parameter frames, the "Single Master" function must be enabled on the NETLink web interface.

In this case, it is necessary to make sure that all CP/CPU combinations are working with the same rack/slot value pairs (stored on the web interface) (in the example above: Rack 0; Slot 2).

Experience has shown that CP-CPU routing works well with "0/2" rack/slot combinations when using CPUs from the 300 series.

In addition, the corresponding parameters in the communications software (SCADA application) need to be configured accordingly. The "Remote TSAP -> Slot numbers" must match those of the corresponding CP address (in the example above: 5, 6, and 7).

10 Troubleshooting

Q: I don't know the IP address of my computer.

A: Enter the command '*ipconfig*' after the prompt to show the configuration of the Ethernet interfaces of your computer.

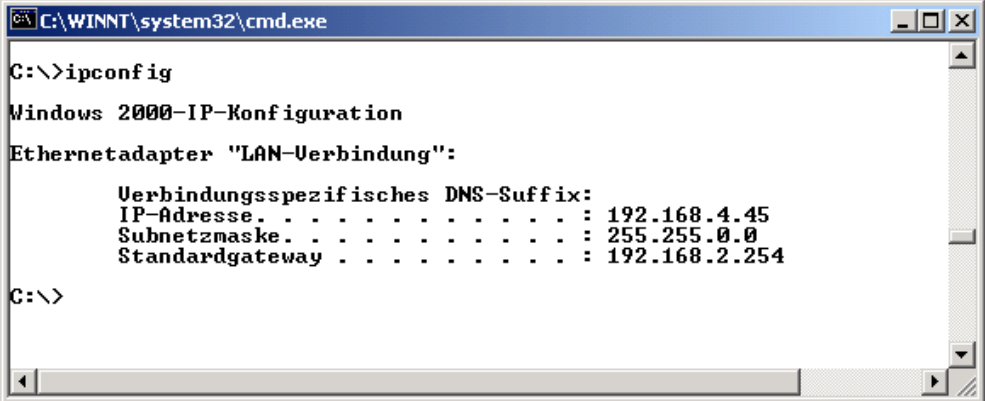

```
C:\WINNT\system32\cmd.exe
C:\>ipconfig
Windows 2000-IP-Konfiguration
Ethernetadapter "LAN-Verbindung":
    Verbindungsspezifisches DNS-Suffix:
    IP-Adresse . . . . . : 192.168.4.45
    Subnetzmaske . . . . . : 255.255.0.0
    Standardgateway . . . . . : 192.168.2.254
C:\>
```

Q: My computer has a firewall. Which ports must I release?

A: The NETLink-S7-NET driver communicates with the NETLink® Gateway via TCP port 7777.

UDP ports 25342 and 25343 are also used to search for the NET-Link® Gateway devices.

Please release at least port 7777 so that the basic functionality of the driver is available.

If you use the RFC1006 functionality (also known as S7-TCP/IP), port 102 must also be released.

ATTENTION: If you want to use the driver option '*Internet teleservice*' (see Section 5.2.1), the specific ports configured there must also be released because this port will be used instead port 7777.

Q: Once the configured PROFIBUS slaves have been added on my CPU, communication between NETLink® Gateway and STEP7 becomes markedly slower.

A: The user can influence the allocation of '*cycle load due to communication [%]*' under object properties of the CPU in the hardware configuration. The default value is 20 %.

Q: When the adapter is plugged on the PROFIBUS, is an online connection not possible?

A: If an active CPU transmits the bus parameters, it would be advisable for you to activate the auto-baud functionality.

If this is not possible or not desired, check the timing parameters for the PROFIBUS in the STEP7 project planning. Enter the read out values into the advanced bus parameter settings with the '*Bus parameters*' button. If online access is still not possible, increase the parameter '*Ttr*' both in the NETLink® and in the CPU by a larger amount.

Make sure you have set the IP address correctly in the driver configuration.

Please also enter the command `PING <IP address>` at the DOS prompt to check whether the NETLink® Gateway can also be accessed physically via the network.

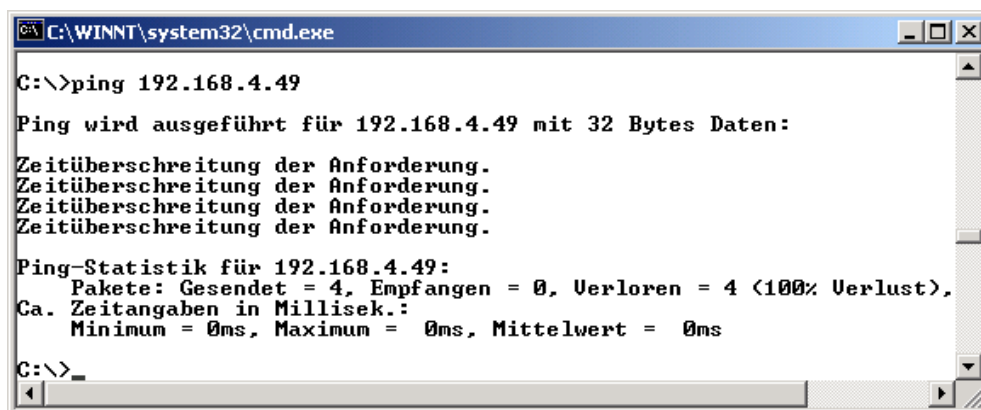

```
C:\WINNT\system32\cmd.exe

C:\>ping 192.168.4.49

Ping wird ausgeführt für 192.168.4.49 mit 32 Bytes Daten:

Zeitüberschreitung der Anforderung.
Zeitüberschreitung der Anforderung.
Zeitüberschreitung der Anforderung.
Zeitüberschreitung der Anforderung.

Ping-Statistik für 192.168.4.49:
    Pakete: Gesendet = 4, Empfangen = 0, Verloren = 4 (100% Verlust),
Ca. Zeitangaben in Millisek.:
    Minimum = 0ms, Maximum = 0ms, Mittelwert = 0ms

C:\>_
```

Q: The setting dialog boxes are not appearing in the Simatic Manager:

A: Please note that after initial installation the NETLink-S7-NET driver must be added to the PG/PC interfaces interfaces (except with Windows 7 operating systems).

Make sure you had administrator rights during installation. Reboot your PC after installation if prompted to do so.

You need at least version 5.1 of the Simatic Manager.

Q: If I set the NETLink® Gateway to auto baud in the PG/PC interface and try to go online, the active LED lights up briefly before a message appears telling me that the bus parameters cannot be determined.

A: Either the CPU used does not support the cyclic transmission of bus parameters (disabled via parameterization or function does not exist), or the CPU is so busy with general communication tasks that the lower-priority bus parameter frame is transmitted too infrequently and cannot be detected by the NETLink® Gateway.

Please deactivate the auto baud functionality in the NETLink-S7-NET driver (PG/PC interface) and set the correct baud rate and the correct profile.

Q: If I mix RFC1006 connections and connections via the STEP7 driver, the link sometimes breaks off or error messages appear saying that it is not possible to establish a link.

A: For communication with S7-300 modules it may be necessary to parameterize the communication resources.

The user can influence the allocation of existing 'connection resources' under object properties of the CPU in the hardware configuration.

Q: The variables from my S7 200 CPU are not updated in my WINCC project.

A: The default settings of the system parameters in register *SIMATIC S7* for *Cycle Formation*, *Sign-of-Life Monitoring* and *CPU-Stop Monitoring* must be deactivated.

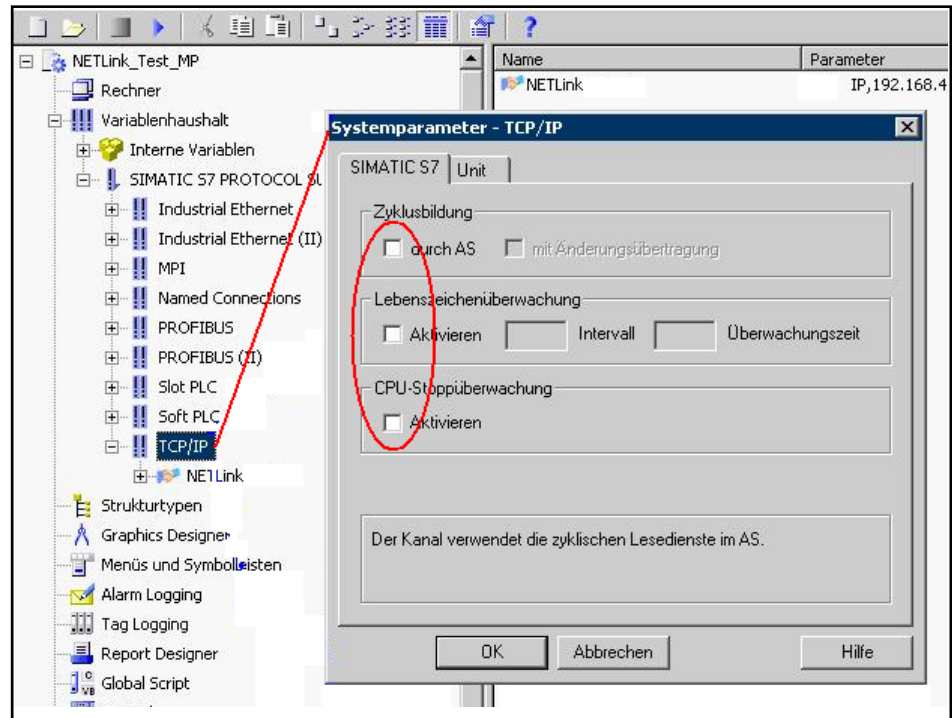

Q: How can I specify the target station(s) for RFC 1006 communications in WinCC by using the Rack/Slot fields?

A: Since the RFC protocol does not have a default entry for specifying the PROFIBUS/MPI address of a target station (PLC), you will have to use the 2 byte-long TSAP field. The first byte of the TSAP ID is the rack value, while the second is the slot value (the value range for the slot field will often have a maximum value of 31, e.g., in WinCC).

This is why the NETLink® unit will have to evaluate both of the TSAP field bytes in order to determine the address of the target station.

Scenario 1: Your application allows slot field values of up to 126

---> You will have to enter “0” into the Rack field and the PROFIBUS address of your CPU into the Slot field.

Scenario 2: Your application only allows slot field values of up to 31

---> You will have to enter a 32x multiplier into the Rack field and the missing remainder of the PROFIBUS address into the Slot field.

Address assignments using the Rack and Slot input fields:

Example 1: Entry for address 17 \triangleq

0	17
---	----

 Calculation: $(0 * 32 + 17)$

Example 2: Entry for address 34 \triangleq

1	2
---	---

 Calculation: $(1 * 32 + 2)$

Example 3: Entry for address 69 \triangleq

2	5
---	---

 Calculation: $(2 * 32 + 5)$

Q: What adjustments must be made in the MCT10 software to realize a communication with Danfoss controllers?

A: The following points should be observed when using a NETLink® gateway:

- Access point in the PG / PC Interface "CP_L2_1" -> NETLink® USB / PRO Family

- "Automatic Baudrate": OFF (= Enable Single Master)

- set the timeout not higher than 20 seconds. (Otherwise the MTC10 software takes a long time to see all the participants because it attempts to connect to each).

Q: I have installed the NETLink-S7-NET driver as described, but receive error messages like the following in the TIA portal:

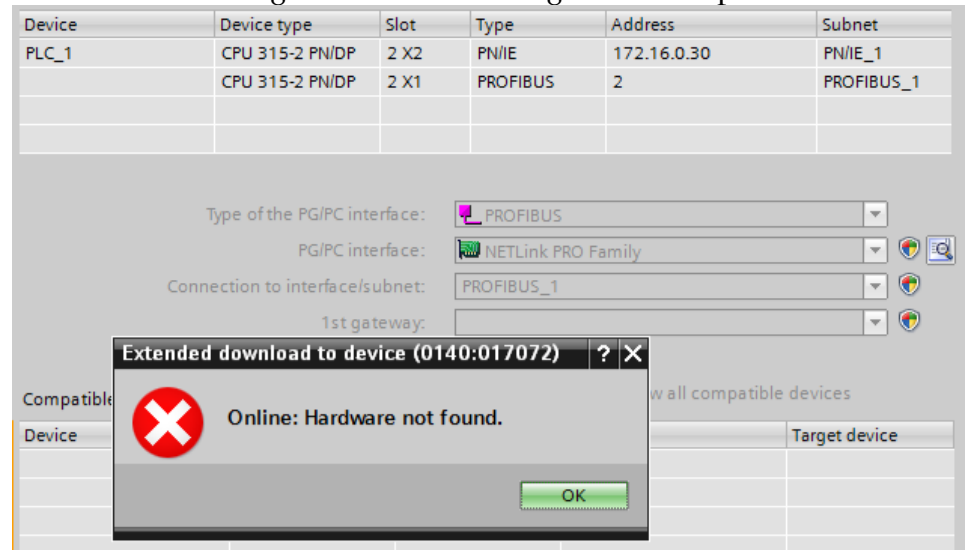

A: The necessary configuration of the NETLink® adapter always takes place through the settings dialogue in the system control element "PG/PC Interface". To this purpose open "Set PG/PC Interface" through the Windows Control Panel. The adapter-specific parameter can in this way also be changed at any time. At least the corresponding IP address and a name must be assigned in the NETLink® setting dialogues.

Q: Is there a hidden button on the NETLink® housing to carry out a factory reset?

A: The resetting of all parameters is only possible with the web interface. To this purpose the http registration data are also required. With the 'Restore Factory Defaults' button it is then possible to restore the delivery state of the NETLink®.

Q: What must I observe when calling your technical support?

A: Please have all relevant data of your system constellation with the connected stations, program modules and status messages at hand when you contact technical support from Helmholtz GmbH & Co.KG.

11 Appendix

11.1 General technical Data

Operating voltage	24 V DC ±25 %
Ethernet interface	10 Base-T / 100 Base-TX, Auto - (MDI)X
Ethernet connection	RJ45 socket
Ethernet transmission rate	10 Mbps and 100 Mbps
MPI/PROFIBUS interface	RS485, electrically isolated
MPI/PROFIBUS transmission rate	9.6 Kbps; 19.2 kbps 45.45 kbps 93.75 kbps 187.5 kbps 500 kbps 1.5 Mbps 3 Mbps 6 Mbps 12 Mbps
MPI/PROFIBUS connection	SUB-D connector, 9-way with programming unit interface
MPI/PROFIBUS protocols	FDL protocol for MPI and PROFIBUS
Degree of protection	IP 20
Ambient temperature	0 °C ... 60 °C
Storage and transportation temperature	-20 °C to +90 °C
Relative humidity during operation	5 % to 85 % at 30 °C (no condensation)
Relative humidity during storage	5 % to 93 % at 40 °C (no condensation)

11.1.1 Technical Data NETLink® PRO PoE

Dimensions in mm (LxWxH)	102 x 54 x 30
Weight	Approx. 180 g
Current consumption	150 mA
Operating voltage PoE	48 V as specified by IEEE 802.3af/at
PoE power level	Class 1 (0.44 to 3.84 Watt)
PoE+	Type 1 (see also 802.3af)
Displays	3 LEDs, including 2 two-color LED, for general status information 2 LEDs at the Ethernetport for Ethernet status

11.1.2 Technical Data NETLink® WLAN

Dimensions in mm (LxWxH)	130 x 68 x 30
Weight	Approx. 280 g
Current consumption	200 mA
WLAN type	802.11b; 802.11g
Antenna terminal	SMA (male)
Frequency range	2,412 – 2,484 GHz
Transmission power	14 dBm + 1,5 dBm/- 1,0 dBm
Bit rate	max. 54 MBit/s
Wireless security methods	WEP, WPA, WPA2
Displays	3 LEDs, incl. 2 two-color, for general status information. 2 LEDs for WLAN status, 2 LEDs on the Ethernet interface for Ethernet status

11.1.3 Technical Data NETLink® PRO Compact

Dimensions in mm (LxWxH)	64 x40 x 17
Weight	Approx. 110 g
Current consumption	200 mA
Displays	2 LEDs, including 1 three-color LED, for general status information

11.2 Pin assignments

11.2.1 MPI/PROFIBUS interface pin assignments

Connector	Signal	Meaning
1	-	Unused
2	GND	Ground power supply (looped through)
3	RxD / TxD-P	Receive / transmit data-P
4	-	Unused
5	DGND	Ground for bus termination (looped through)
6	DVCC	5 V DC for bus termination (looped through)
7	VCC	24 V DC for power supply (looped through)
8	RxD / TxD-N	Receive / transmit data-N
9	-	Unused

11.2.2 Assignment of the Ethernet interface (host interface)

Connection	Signal	PoE Power Supply*	Meaning
1	TX+	P – DC+	Transmit data / phantom power*
2	TX-	P – DC+	Transmit data / phantom power*
3	RX+	P – DC-	Receive data / phantom power*
4		S – DC+	Spare Pair Supply*
5		S – DC+	Spare pair supply*
6	RX-	P – DC-	Receive data / phantom power*
7		S – DC-	Spare Pair Supply*
8		S – DC-	Spare pair supply*

* only with NETLink® PRO PoE

All NETLink® Gateways comes with a shielded cross-over category 5 TCP cable with a length of three meters.

The maximum cable length between two TCP interfaces is 100 meters according to IEEE802.

If distances greater than 100 meters have to be covered, the use of switches or hubs is recommended.

11.2.3 Power supply socket

If an external power supply is used, please make sure the polarity is correct and all technical data are complied with.

11.3 Further documentation

In addition to this manual, you will always find further information or new and revised versions at: www.helmholz.de.

Selection as of 08/2011:

- Extended NETLink® functions - Project-specific interface
- Communication with OPC, SCADA, HMI - Application examples with RFC 1006
- Extended NETLink® functions – CPU-to-CPU communication

11.3.1 Information in the internet

<http://www.helmholz.de>

<http://www.profibus.com>

<http://www.siemens.com>

<http://www.poweroverethernet.com>

<http://www.ietf.org/rfc>

11.3.2 Further information

Publication from BSI to the issue „Drahtlose Kommunikationssysteme und Ihre Sicherheitsaspekte“

Technical rules 2185 from the VDI/VDE alliance to the issue „Funkgestützte Kommunikation in der Automatisierungstechnik“.

11.3.3 Address conversion table

The following table is a parameterization aid for finding the correct setting for Routing over RFC or for remote TSAP in addressed mode. Please note that the rack and slot together fill only one byte which is divided as follows:

- Rack fills the upper three bits (11100000_{bin})
- Slot fills the lower five bits (00011111_{bin})

Bus-addr.	Rack	Slot	TSAP	Bus-addr.	Rack	Slot	TSAP	Bus-addr.	Rack	Slot	TSAP	Bus-addr.	Rack	Slot	TSAP
0	0	0	0200	32	1	0	0220	64	2	0	0240	96	3	0	0260
1	0	1	0201	33	1	1	0221	65	2	1	0241	97	3	1	0261
2	0	2	0202	34	1	2	0222	66	2	2	0242	98	3	2	0262
3	0	3	0203	35	1	3	0223	67	2	3	0243	99	3	3	0263
4	0	4	0204	36	1	4	0224	68	2	4	0244	100	3	4	0264
5	0	5	0205	37	1	5	0225	69	2	5	0245	101	3	5	0265
6	0	6	0206	38	1	6	0226	70	2	6	0246	102	3	6	0266
7	0	7	0207	39	1	7	0227	71	2	7	0247	103	3	7	0267
8	0	8	0208	40	1	8	0228	72	2	8	0248	104	3	8	0268
9	0	9	0209	41	1	9	0229	73	2	9	0249	105	3	9	0269
10	0	10	020A	42	1	10	022A	74	2	10	024A	106	3	10	026A
11	0	11	020B	43	1	11	022B	75	2	11	024B	107	3	11	026B
12	0	12	020C	44	1	12	022C	76	2	12	024C	108	3	12	026C
13	0	13	020D	45	1	13	022D	77	2	13	024D	109	3	13	026D
14	0	14	020E	46	1	14	022E	78	2	14	024E	110	3	14	026E
15	0	15	020F	47	1	15	022F	79	2	15	024F	111	3	15	026F
16	0	16	0210	48	1	16	0230	80	2	16	0250	112	3	16	0270
17	0	17	0211	49	1	17	0231	81	2	17	0251	113	3	17	0271
18	0	18	0212	50	1	18	0232	82	2	18	0252	114	3	18	0272
19	0	19	0213	51	1	19	0233	83	2	19	0253	115	3	19	0273
20	0	20	0214	52	1	20	0234	84	2	20	0254	116	3	20	0274
21	0	21	0215	53	1	21	0235	85	2	21	0255	117	3	21	0275
22	0	22	0216	54	1	22	0236	86	2	22	0256	118	3	22	0276
23	0	23	0217	55	1	23	0237	87	2	23	0257	119	3	23	0277
24	0	24	0218	56	1	24	0238	88	2	24	0258	120	3	24	0278
25	0	25	0219	57	1	25	0239	89	2	25	0259	121	3	25	0279
26	0	26	021A	58	1	26	023A	90	2	26	025A	122	3	26	027A
27	0	27	021B	59	1	27	023B	91	2	27	025B	123	3	27	027B
28	0	28	021C	60	1	28	023C	92	2	28	025C	124	3	28	027C
29	0	29	021D	61	1	29	023D	93	2	29	025D	125	3	29	027D
30	0	30	021E	62	1	30	023E	94	2	30	025E				
31	0	31	021F	63	1	31	023F	95	2	31	025F				

12 Glossary

These are explanations of the most important technical terms and abbreviations from the manual:

128 Bit:	Means in this manual the encoding of WLAN data using a code of 128 bit. That adds to a total of $3 \cdot 10^{38}$ different keys
64 Bit:	Means in this manual the encoding of WLAN data using a code of 128 bit. That adds to a total of $1 \cdot 10^{19}$ different keys
802.11b:	IEEE standard that allows gross transfer rates up to 11Mbps in WLAN
802.11g:	IEEE standard, a succeeding model of 802.11b that allows gross transfer rates up to 54 Mbps in WLAN and that is compatible to 802.11b
Ac- cessPoint:	Central access point for WLAN devices that are used in the infrastructure mode. Controls sending and receiving within a radio cell
Ad-hoc:	WLAN mode that functions like a peer to peer network in order to connect WLAN devices directly with each other without the involvement of an access point
Advanced PPI	The extension of the PPI protocol of the S7-200 series. Normally only compatible with CPUs of the S7-22x series and higher
AES:	Advanced Encryption Standard, an encoding standard similar to TKIP for WPA2
ANP	see Auto negotiation
ASCII	American Standard Code for Information Interchange describes a character set that includes the Latin alphabet in upper and lower case, the ten Arabic numerals, as well as some punctuation marks and control characters
Authen- tication:	Authentication is used to check if a device is device it pretends to be. Example: NETLink® WLAN authenticates itself at the access point
Autobaud	Also called "auto sensing," is a function supporting automatic adjustment of the baud rates in a network
Auto nego- tiation	ANP describes a function that automatically recognizes and configures communication partners in the network
Autouplink :	A feature used by switch ports to automatically detect whether they are connected to another switch or to a terminal.
Baudrate	The speed set on a bus system
Bit	Binary digit describes the smallest digital information unit. Defines 0 or 1
Broadcast	Data packet transmitted to all stations in a network
Browser	Also known as Web browser, is a program for viewing Internet pages. In addition to addressing and referencing other positions in the text, a graphical user interface be displayed, for example Web interface.
BSS:	Basic Service Set describes the set-up of at least 2 WLAN stations such as NETLink® WLAN and an access point or a WLAN adapter
BUS	Buses are connection systems for electronic components. For example, the MPI Bus is a connection medium for S7
Byte	A byte denotes a series of 8 bits that constitute a logical data entity
CAT5-TCP- Kabel	Category 5 Ethernet cable that supports a data rate of 100 Mbps over a distance of 100 m

Channel:	Transmission frequency that is to be used in the ad hoc mode. The access points provide the channel in the infrastructure mode
Client	A device that requests services. The requests are sent to a server, which returns the relevant answers to the client.
dBi:	Antenna gain in decibel with regard to an isotropic radiator
DHCP	Dynamic Host Configuration Protocol, DHCP server can dynamically pass an -> IP address and other parameters to DHCP clients on request.
DNS	Domain Name System is a shared database system in LAN as well as in the internet that transforms IP addresses into plain text addresses
Domain name	The domain is the name of an Internet page. It consists of the name and an extension. The domain of Helmholtz is: www.helmholtz.de
Encryption:	Encryption is the general term for encoding procedures
Endspan	The Endspan device is also usually a switch which, as PSE, has the PoE functionality.
Firewall	A service running on a server that blocks certain services/ports and prohibits unauthorized access
Flow Control:	A process that sends a break frame if the data buffer is almost full.
Gap	The Gap Update Factor specifies after how many token cycles the master checks whether an additional master is signaling its presence on the bus
Gateway	This is a machine that works like a router. Unlike a router, a gateway can also route data packets from different hardware networks.
HMI	Human-Machine Interface denotes the interface between the human operator and a system through which the operator can operate the system or intervene in the process
Hex:	A key for NETLink® WLAN that is entered in hexadecimal notation
HSA	Highest station address that is polled
Hub	A mediation system between LAN segments. Unlike a switch, on a hub, all data arising in the Ethernet are applied to all ports
Infrastructure:	Operation type according to WLAN standard IEEE 802.11 that needs an access point. The access point is generally linked to an internal firm network via LAN in this mode
Interfaces	General definition of interfaces, such as a network interface card that constitutes an Ethernet interface
IP address	Internet protocol address. The IP is the address of a device in a network at which it can be reached. It consists of four bytes and is expressed in decimal notation. Example: 192.168.4.49
ISO on top of TCP	see RFC1006
Keytype:	Character set that is to be used for the key. HEX or Passphrase (ASCII)
LAN	Local area network, a network of computers that are relatively close to each other physically.
MAC-Adresse	The Media Access Control address is used only once for each single network component that is not changeable. It consists of 6 bytes and is written in

	hexadecimal notation. Example: 08-FF-FA-9C-ED-5A
Master	Is an active station that is permitted to transmit data and request data from other stations, when it holds the token
MDI / MDI-X Auto Cross-Over	Makes it possible to identify if a cross over or a straight cable is connected and configures the port accordingly.
Midspan	Midspan devices are also installed between a none-PoE-compatible switch and a PD as injector for PoE supply. This type of device must be powered from the mains.
MLFB	16-digit Siemens identification number
MPI	Multipoint Interface. Interface that is used for S7-300 and S7-400 systems and that supports baud rates up to 1.5 Mbps
NAT	Network Address Translation is the collective term for procedures for replacing address information in data packets by other address information in an automated and transparent way. This is very useful when connecting private networks via a public line.
Network rules	Network rules determine how the different data packets are handled in a network device. For example, data packets are blocked or forwarded to or from certain network stations
Omni-Antenne:	A rod-shaped antenna that radiates equally in all directions. They are usually intended for the use in buildings or outside and radiate the building in all directions
OPC	Object Linking and Embedding for Process Control allows data transfer between applications of different producers, for example, using the RFC1006 protocol
Open/None:	Authentication according to the "Open/None" method without the exchange of authentication data in the WEP encoding mode. Is said to be safer than „Shared“, since the key of the latter can be extracted by “sniffing”
Panel-Antenne:	A usually flat antenna that radiates strongest in the respective direction. They are usually used where a big distance has to be bypassed
Passphrase:	Describes a character set that can be used to save data from hackers in the encoding mode. Here the characters A-Z, a-z as well as 0-9 and the ASCII digits 33-126 can be used without hesitation
PAT	Port address translation. Used when multiple private IP addresses of a LAN need to be translated into one public IP address
PD	Acronym for “Powered Device,” a device that consumes energy as per the PoE standard.
PG socket	The programming unit socket of the bus connector allows further bus nodes to be plugged in.
Phantom supply	In PoE a technique used in 1000Base-T Ethernet to distribute power over the same wires as are used to transport data
PoE/PoEplus	Two different performance classes in Power over Ethernet IEEE 802.3af (POE) and IEEE 802.3at (POE+).
Port	These are address components that are used in network protocols to assign the correct protocols to data segments, also using port forwarding.
Port For-	The passing on of requests to ports via a network.

warding	
PPI	Point-to-point interface, interface with S7-200 systems with a maximum baud rate of 187.5 kbps
PROFIBUS	Process Field Bus is the protocol that is used mainly for automation, e.g. for the S7-300 and S7-400 systems with a maximum baud rate of 12 Mbps
Profinet	Standard for industrial Ethernet in automation.
Proxy	System used for buffering. Requests can be faster via a proxy this way, and the system load is reduced at the same time. Primarily used to separate local network and WWW
PSE	Abbreviation for Power Source Equipment Energy supplier according to the PoE standard
Rack/Slot	Rack refers to the configured module rack (default: 0) and slot, to the slot for the module in question (default CPU: 2). The default configuration for an R/S is therefore 0/2
Radio cell:	The area that is covered by an access point via antenna. Logged-on WLAN clients can connect to the access point within this area
Resistive Power Discovery	A technique defined by the PoE standard for automatically recognising PoE-capable and non-PoE-capable devices. The autonomous differentiation by the PSE serves to protect all connected network devices
Retry limit	Bus parameter that determines the number of attempts which are made to call a DP slave.
RFC1006	Request for comment is a type of protocol. It defines the way an ISO packet is transported in a TCP data packet as <i>"useful load"</i> .
RJ45 socket:	A network socket with 8 wires according to the RJ plug system.
Router	This is a machine that ensures in a network that the data of a protocol arriving at it are forwarded to the intended destination network or subnet.
Routing	Means a set function that mediates messages and data respectively between LANs, WANs, MPI and PROFIBUS.
S7-TCP/IP	Interface parameterization in the PG/PC interface that is based on TCP/IP and that is handled via the selected network interface card of the PC.
SCADA	Supervisory Control and Data Acquisition. Generic term for a type of process visualization that includes monitoring, control, and data acquisition of automation systems, etc.
Server	Device that provides specific services on request of the clients.
Single Line Injektor	See Midspan.
Single Master	Only one master is connected to the system. The NETLink® family members WLAN, Switch, and PRO Compact can also act as single masters.
Shared:	WEP authentication method. First, the WLAN party sends a request for authentication to an access point. Hereupon, the access point sends a generated series of characters. The WLAN party encodes the series of characters with the entered key and returns the answer to the access point. Hereupon, the access point should accept the answer and send an authentication code that allows the

WLAN party to log on the access point.

Slave	A station that is only permitted to exchange data with the master if requested to do so by the latter.
SMA:	Subminiature. A microwave plug or a microwave socket that is used for HF and microwave techniques as well as in WLAN due to its robustness.
Socket	Data links that are created by means of ->TCP or ->UDP work with sockets for the addressing purposes. A socket consists of an IP address and a port (cf. address: street name and house number).
Spare Pair Supply	The power supply for PoE is distributed over the 4 unused free wires in CAT 5 networking cable (wire pairs 4/5 and 7/8).
SSID:	Service Set Identifier. Name of a radio cell and an ad hoc device in a WLAN network respectively. It is here possible, too, to use ASCII characters A-Z, a-z, 0-9 and the special characters 33-126.
Subnetz maske	Determines the net and host share of the IP address. Allows the classification of address areas and prohibits the direct access to other nets.
Switch	A device that can connect multiple machines with Ethernet. Unlike a hub, a switch is " <i>smart</i> " in that it can remember the MAC addresses that are connected to a port and routes the traffic more efficiently than the individual ports.
TCP/IP	The Transmission Control Protocol is a transport protocol to permit data exchange between network devices. IP is the extension for Internet Protocol.
Timeout	Is a protocol assignment which will be activated if a preset time is exceeded.
Token	Is a telegram for the send authority of a network which will be hand off from master to master.
TKIP:	Temporal Key Integrity Protocol is a data coding method for WPA.
Tqui	Transmitter fall time (bit) is the time that is needed to restore the quiescent signal level on the signal line after transmitting data.
TSAP	Transport Service Access Point. The TSAP corresponds to the layer 4 address that has to match crossed-over for a station and the communication partner to be reached. The remote TSAP of Station1 is equivalent to the local TSAP of Station2. Entry of any characters, e.g. numerals is possible
Tsdr	Protocol processing time of the responding station (station delay responder).
Tset	The Setup time (Bit) is the time which is allowed to elapse between sending and receiving telegrams.
Tslot_Init	The Slot time (Bit) is the maximum time which is allowed to pass for a answer of the spoken device afore.
Ttr	The Target rotation time (Bit) is the reference token time which means there is a comparison between the actual token time and the reference token time. It depends on how many time is available to the master for sending his own telegrams to the slaves.
UDP	User Datagram Protocol, transport protocol permitting data exchange between network devices. It is a connectionless protocol, that is, data transmission is performed without error detection.
URL	" <i>Uniform Resource Locator</i> ," denotes the address at which a service can be found in the Web browser. In this manual, the IP address of the NETLink® PRO Compact is usually entered as the URL.

VPN	Virtual Private Network. Logical links, called tunnels, are established over existing unsecured networks. The end points of these links (“ <i>tunnel ends</i> ”) and the devices behind them can be thought of as a separate, logical network. A very high level of security against tapping and tampering can be achieved if data transmission via tunnels is encrypted and the stations in this logical network first authenticate each other.
WAN	Wide Area Network, a network of computers that are physically far apart. The internet is the largest known WAN.
Web- Interface	Is opened using a browser. It contains the data and functions to be able, for example, to interact with the NETLink® PRO Compact.
WEP:	Wired Equivalent Encryption is the first encryption standard for WLAN networks and depends on the RC4 algorithm. For this function the static keys have to be inscribed in every station.
WLAN:	Wireless Local Area Network is a network of clients which are able to connect with each other or to an access point by radio communication.
WPA:	Encryption mode which is used as a workaround from WEP to WPA2. Compared to WEP this one is enhanced with a dynamic encryption named TKIP.
WPA2 /802.11i:	The second version of WPA with better encryption and authentication algorithm.
WWW	World Wide Web. Worldwide communication network, also known as the Internet.